



HZ-500
Haze Machine
User Manual
- English
- 中文





1. Introduction	1
2. Safety Information	1
3. Package Contents & Inspection	2
4. Machine Details	3
5. Technical Label Information	3
6. Haze Fluid	3
7. Setting and Manual Operation	4
8. Control Settings	4
9. DMX Connection.....	5
10. Service and Maintenance.....	5
11. Technical Specifications.....	6
12. Warranty Disclaimer	6
13. Machine Dimension.....	6
1. 前言	7
2. 安全注意事項	7
3. 包裝內容與檢查	8
4. 機器訊息.....	9
5. 技術標籤資訊	9
6. 煙霧水.....	9
7. 設定與手動操作說明.....	10
8. 控制設定.....	10
9. DMX 說明.....	11
10. 維護和保養	11
11. 技術規格.....	12
12. 保固聲明.....	12
13. 機器尺寸圖	12
Appendix I Grounding Instruction.....	13

Hazer Technology **HZ500** User Manual

1. Introduction

Please read all the user manual before operating the machine, and place the manual where the user can refer to it at all time. The manual includes how to install and operate the machine under safe conditions and explain all the labels printed on the machine. If you encounter any problem, contact your local Antari dealer for assistant immediately.

2. Safety Information

 DANGER	If the danger is not avoided, it will cause death or serious injury
 WARNING	If the warning is not heeded, it can cause death or serious injury.
 CAUTION	If the precaution is not taken, it may cause minor or moderate injury.



DANGER

- Must connect the machine to the correct rated voltage or it might lead to an electrical shock or a burn and may cause serious consequences.
- Must connect the machine to a protected circuit and ensure it is properly grounded to avoid the risk of electrocution. For grounding instruction, please refer to Appendix I on page 13.
- Do not operate the machine with a bundled power cord, it could lead to a fire hazard.
- When operating the machine, do not point at people, animals, or fire.



WARNING

- Please operate the machine on a flat, level hard and well ventilated surface area, reserve at least 50cm space around the machine and make sure there is no flammable gas or material nearby.
- Do not disassemble, repair or modify the machine, it may cause damages, malfunction, risk of electrical shock or result in fire.
- The machine can only be operated by adults or professionals, is not intended for use by person with reduced physical sensory, mental capabilities, or lack of experience and knowledge including children.
- Do not leave the machine running unattended, make sure all powers are off when leaving.
- Children should be supervised to ensure that they do not play with the machine.
- Do not use the machine upside down or tilt it, it might cause damages or malfunction.
- Please store the fluid inside in a well ventilated area without direct sunlight and keep out of reach of children. In case of eye contact or accidentally swallow the fluid, please seek medical attention immediately.



CAUTION

- Keep the machine dry at all time. The machine is not waterproof, do not expose the machine to water, rain or moisture environment.
- Please make sure the power outlet is not damaged or loose before plug in the power cord.
- If the power cord is damaged, it must be replaced by Antari or its local dealers, otherwise the warranty will be void.
- Before transporting the machine, please make sure the fluid is drained and tank is empty. (Recommend using original package)
- The machine is for indoor use only.
- Do not operate the machine in any area with unstable voltage.

- If you experience strange sound or malfunction, turn off the power and unplug the power cord immediately and contact your local Antari dealer for assistant.
- Do not contact any moving part.
- Only use accessories recommended or sold by Antari.
- Please make sure the power is off when not using the machine and unplug the power cord if not intend to use for a long period of time.
- To disconnect, turn all controls to the off position, then remove plug from outlet.
- Do not unplug by pulling on cord. To unplug, grasp the plug, not the cord.
- Unplug from outlet before servicing or cleaning.
- Do not operate the machine with a damaged cord or plug, or after the machine malfunctions or is dropped or damaged in any manner. Return machine to the nearest authorized service facility for examination, repair, or electrical or mechanical adjustment.
- Please do not allow magnetic equipment close to the haze outlet door, magnetic equipment could cause door sensor malfunction.
- To ensure the lifespan of the machine, please only use the fluid manufactured by Antari, do not use other fluid or additive, otherwise it may cause malfunction.

Before operating the machine, please read all warning labels on the machine, description as below;

Top Panel Printing

WARNING!

- After refilling, please wait 5 mins, enabling all haze liquid to fill the tank entirely prior to switching on.
- For the first refill, please add 2 litres of haze liquid.
From the second refill on, please add 1 litre haze liquid with every refill
- Please do not overfill the haze liquid. Make sure the liquid level does not exceed the mark
- Please use dealer recommended haze fluids only.

CAUTION

TO REDUCE THE RISK OF FIRE, REPLACE ONLY WITH SAME SIZE AND TYPE OF FUSE

3. Package Contents & Inspection

Immediately upon receiving the machine, carefully unpack the carton, check the content to ensure it is the correct model and all parts are included. If any part appears to be damaged or missing during transportation, please contact your local dealer and return in original package for inspection.

3.1 Package Contents

- 1 x HZ-500 Haze Machine
- 1 x IEC Power Cable
- 1 x Quick Start Guide

3.2 Optional Accessories

Item Code	Description
N/A	N/A

4. Machine Details

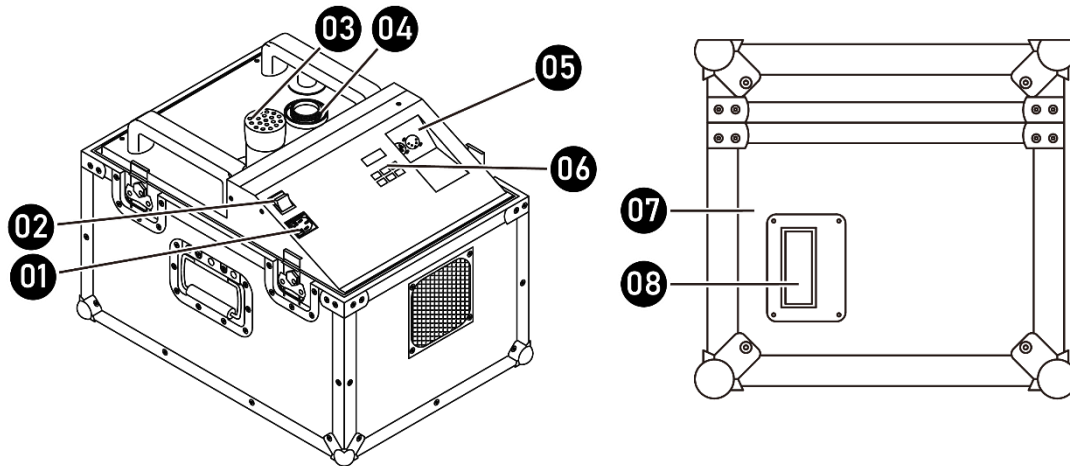

01. IEC Power Connector	05. XLR 5-Pin Connector DMX
02. Power Switch	06. Onboard Digital Control Interface
03. Nozzle/Fluid Inlet	07. Flight Case
04. Seal Cap	08. Fluid Indicator

5. Technical Label Information

Please read the technical label information on the back of the machine before operating it.

1. Model Name	5. Breaker/Fuse
2. Input Voltage	6. QR CODE for User Manual
3. Frequency	7. Serial No.
4. Rated Power	

6. Haze Fluid

	CAUTION	Always turn off the power before filling the fluid tank. Do not add flammable liquid to the fluid tank. If fluid gets inside the machine, please contact your local Antari dealer for assistant.
--	----------------	--

- Only the haze fluid manufactured by Antari can be used, do not mix or dilute the haze fluid. Due to improper storage or using other fluid might cause malfunction.
- The machine is tested and calibrated with the specific haze fluid to get the best performance.
- Please empty the fluid in the tank before switching to another fluid to avoid mixing.
- The warranty on your haze machine will be void if you use haze fluid not manufactured by Antari.

7. Setting and Manual Operation

	WARNING	Machine falling off might cause serious injury, please make sure it is secure and firm on the overhead.
---	----------------	---

- Step 1.** Place the machine on a flat, level hard and well ventilated surface area and reserve at least 50cm open space around the machine, and make sure there is no flammable gas or material nearby;
- Step 2.** Fill with Antari approved haze fluid;
- Step 3.** Connect the machine to the power outlet. Please read the technical label on the back of the machine and make sure the power outlet is the correspond to the rated voltage for the machine;
- Step 4.** Turn on the power, make sure the RED indicator light is on. Once the machine is ready for operation, the LCD display will show “Ready To Haze”;
- Step 5.** To start hazing, press [MANUAL] button and to stop hazing, release [MANUAL] button;
- Step 6.** To start hazing, press [VOLUME] button and to stop hazing, press [VOLUME] button again;
- Step 7.** To start hazing, press [TIMER] once and to stop hazing, press [TIMER], this will run based on “interval” & “duration” setting in the main menu;
- Step 8.** To turn off the machine, please make sure the machine is not operating then turn of the power. If you will not use the machine a long period of time, please remove the power cord.

8. Control Settings





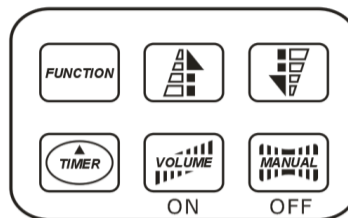

HZ-500 Haze Machine can be operated in the following modes. The machine can only accept 1 type of signal at a time.

- Manual
- Timer
- DMX512

8.1 Control Panel Description



HZ-500 Haze Machine can be operated with the onboard digital control interface.

Button	Operating Method	Action
 Menu	Press	To enter setting menu
 Up	Press	Increase value
 Down	Press	Decrease value
 TIMER	Press	1. Press to start hazing according to the set time 2. Press “stop” to stop hazing
 ON	Press	1. Press to start hazing 2. Press “stop” to stop hazing
 OFF	Press	1. Press once to choose function in set menu 2. Leave setting menu 3. Stop hazing

8.2 Menu Options Description

Options	Description
Interval	Set Interval between 1-200 sec
Duration	Set Duration between 1-200 sec
DMX512 Add.001	001-512
Door Sensor	On / Off (See Note 1)
Direct Haze	On / Off

Note 1: If door sensor is on (Screen show DOOR ON SENSOR). A warning alarm will sound when the machine is activated and the door is not open completely. The screen will flash and show “DOOR CLOSED” and machine will resume function after the door is opened completely.

Note 2: In Direct Haze mode, the machine will start hazing after power is on, to stop hazing, press [MANUAL].

Note 3: If the display showed “Out Of Order”, means machine’s internal temperature is too high and the machine will shut down. Please check the following things to solve the issue,

1. Please check the filter on the back of the machine, make sure it’s clean and no debris.
2. Check the surrounding temperature, if it’s too high, please move the machine to a well ventilated space.

9. DMX Connection

9.1 DMX Connector Pin Assignment

The machine has a XLR 5-Pin for DMX connection. The diagram below indicates pin assignment information.

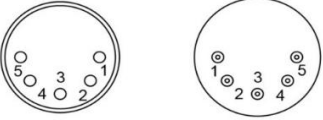
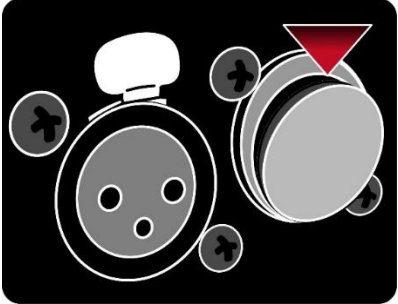
 <p style="text-align: center;">5 Pin XLR</p>		<p>** There is a protection cap on DMX IN, please remove it with your finger before operation.</p> 
Pin	Function	
1	Ground	
2	Data-	
3	Data+	
4	N/A	
5	N/A	

9.2 DMX Channel Function

DMX Value	Function
0~250	Off
251~255	On

10. Service and Maintenance

 <p>DANGER</p>	<p>Disconnect the power cord before starting maintenance operation!</p>
--	---

- Always keep the machine clean.
- Can use an air compressor, a vacuum or a soft brush to remove the dust on the machine.
- Can use a slightly damp cloth to clean the casing.
- Before store or after each use, please make sure the fluid tank is clean and dry.
- It is recommended to run the machine at least once a month in order to maintain its best performance and output condition.

- Excessive dust and build up liquid residue will reduce the performance and cause overheat.

11. Technical Specifications

	HZ-500
Input Voltage	US Model : AC 100-120V, 50/60Hz 3.5A EU Model : AC 220-240V, 50/60Hz 2.0A
Rated Power	120V 400W 240V 480W
Fluid Consumption	1.1 ml/min (100% output)
Fluid Tank Capacity	2.5 Liters (0.66 gallon)
Compatible Fluid	Antari HZL Haze Fluid 、 Antari HZL-W Haze Fluid
Operating Time	37 hrs (100% output)
Ambient Temp. Range	0°C – 40°C (32°F – 104°F)
Control Methods	Manual 、 Timer 、 DMX512
Interface	XLR 5-Pin Connector (DMX) 、 IEC Connector (Power)
DMX Channels	1 Channel
Included Accessories	N/A
Optional Accessories	N/A
Dimension	L 515W 375 H 355 mm (L 20.28 W 14.77 H 13.98 inch)
Weight	31.5 kg (69.45 lbs.)

12. Warranty Disclaimer

We guarantee the merchandise manufactured by us to be free from defect in material and workmanship for a period of one year. Our obligation and liability under this warranty shall be restricted to repair or replacement at our factory or local authorized dealer. We assume no liability of the products that are improperly used or used for any purpose other than that for which they are specially designed. This warranty shall not apply to any merchandise which has been repaired, altered or assembled outside our factory in any way so as in our judgment to affect its performance, nor which has been subjected to misuse, negligence, or accident nor to any merchandise operated contrary to our printed instructions. We will not allow or be liable of any loss or any damages of any kind in connection with the use, sale, or repair of any merchandise purchased from us.

13. Machine Dimension

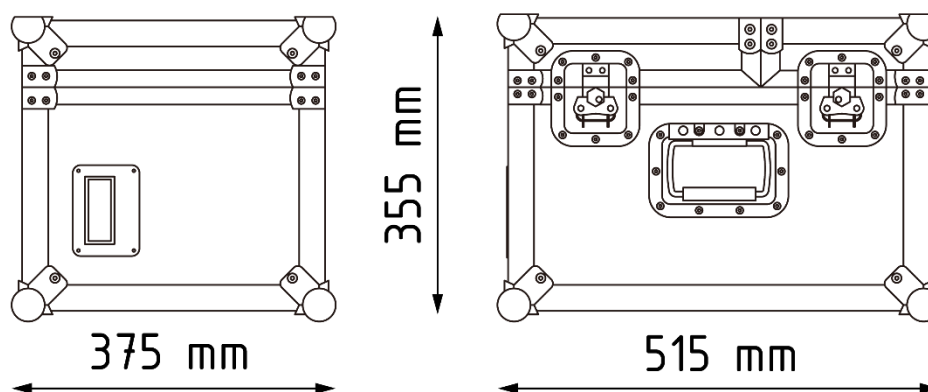



Hazer Technology HZ500 中文使用說明書

1. 前言

在操作本機器之前，請務必仔細詳閱本說明書然後請將本說明書放置在機器使用者可隨時查閱之處存放。此說明書包含如何安全的安裝及操作本機器以及說明所有在機器上的標示。如果您有任何操作上的問題，請立即聯繫當地的 Antari 經銷商尋求協助。

2. 安全注意事項

 危險	若不確實避免這些指示，可能導致嚴重人身傷害甚至死亡。
 警告	若不確實遵循這些指示，可能導致嚴重人身傷害甚至死亡。
 注意	若不確實注意這些指示，可能導致人身傷害甚至死亡，嚴重程度視情況而定。

危險

- 請務必使用正確電壓。如果使用錯誤電壓，可能會遭受危險的電擊燒傷或更嚴重的後果。
- 請務必將機器連結到有保護的電路，並確保有正確地接地，以避免觸電的危險。關於接地方式請參考第 13 頁附錄 I。
- 請勿在捆綁電源線的情況下使用，可能會發熱導致火災。
- 操作機器時請勿將機器對著人體、動物或火焰使用。

警告

- 請於堅固、平坦、穩定且通風良好的表面上使用機器。請勿遮蓋機器散熱部份，機器周邊至少應保留 50 公分的空間並確認附近沒有易燃性物質或可揮發性氣體。
- 請勿隨意拆卸、修理或改造機器，這可能會導致機器故障、損壞、觸電危險或造成火災。
- 本機器僅限有行為能力之成人或專業人員操作，不預期提供生理、感知、心智能力、經驗或知識不足者之使用者(包含孩童)使用本機器。
- 請勿在無人看管時讓機器運作，並於外出離去時確實關閉電源。
- 孩童應受監督，以確保孩童不能操作或嬉戲玩本機器。
- 請勿將機器倒放或傾斜使用，可能導致機器動作不正常或損壞。
- 請將液體存放在室內孩童無法取得之處，保持通風及避免陽光直射。如果有觸碰眼睛或誤食機器，請立即尋求醫生的協助。

注意

- 本機器無防水設計，請隨時保持機器乾燥，嚴禁將其潑水、浸水、淋雨或放在潮溼的環境。
- 在插入電源插座前，請確認電源插座無損壞或鬆動。
- 若電源線損壞，必須使用原廠電源線或組件進行更換，否則將導致保固無效。
- 在運輸本機器前，請確認機器的油箱已清空並且包裝完整。(建議使用原廠包裝)
- 本產品僅限室內使用。
- 請勿在電壓不穩定的地區使用本機器。
- 如果機器出現異常聲音或有任何不正常現象時，請立即停止工作，將電源關閉及拔下機器電源線，並請聯繫當地的 Antari 經銷商尋求協助。

- 請勿觸碰機器內部運轉零件。
- 只能使用原廠建議或販售之配件。
- 請確認機器不在使用的狀態下電源已關。如果長時間不使用機器，請拔掉電源線。
- 關閉機器時，將所以控制開關轉到關閉的位置，然後再將插頭從插座拔除。
- 拔除電源線時，請抓住插頭不是電線。
- 在保養及清潔前，請把電源線從插座拔除。
- 在電線或插座有損毀、機器故障或有掉落或損壞的情形發生時，請勿操作機器。請將機器送回最近的維修站，做檢查、維修及電源或機械的調整。
- 出煙口門蓋周圍嚴禁放置有磁性的物品避免開口感測器故障。
- 為確保機器的使用壽命，請使用 Antari 原廠製造之煙霧水，勿使用其它非 Antari 原廠製造煙霧水或添加劑，否則可能會導致故障。

在使用本機之前，請詳細閱讀機器上的警語標示，說明如下：

上蓋印刷

WARNING! 警告!

- After refilling, please wait 5 mins, enabling all haze liquid to fill the tank entirely prior to switching on.
補充煙霧水後，請等待 5 分鐘，讓煙霧水完全流入儲液槽後再開機
- For the first refill, please add 2 litres of haze liquid. 第一次補充時，請加入 2 公升煙霧水
From the second refill on, please add 1 litre haze liquid with every refill
從第二次補充開始，每次請加入 1 公升煙霧水
- Please do not overfill the haze liquid. Make sure the liquid level does not exceed the mark
請勿過量加入煙霧水，液面不可超過標示線
- Please use dealer recommended haze fluids only.
請僅使用經銷商推薦之煙霧水

CAUTION 注意

TO REDUCE THE RISK OF FIRE, REPLACE ONLY WITH SAME SIZE AND TYPE OF FUSE
為降低火災風險，請僅更換為相同尺寸與類型的保險絲

3. 包裝內容與檢查

在收到機器後，請立即小心地打開包裝紙箱，檢查所有內容，確認您所購買的機型及配件。如果有任何部件因運輸過程出現損壞或缺少，請立即連絡經銷商，並以原包裝退回檢查。

3.1 包裝內容

- 1 x HZ-500 薄霧型特效煙機
- 1 x IEC 電源線
- 1 x 快速入門指南

3.2 選配說明

品項	
N/A	N/A

4. 機器訊息

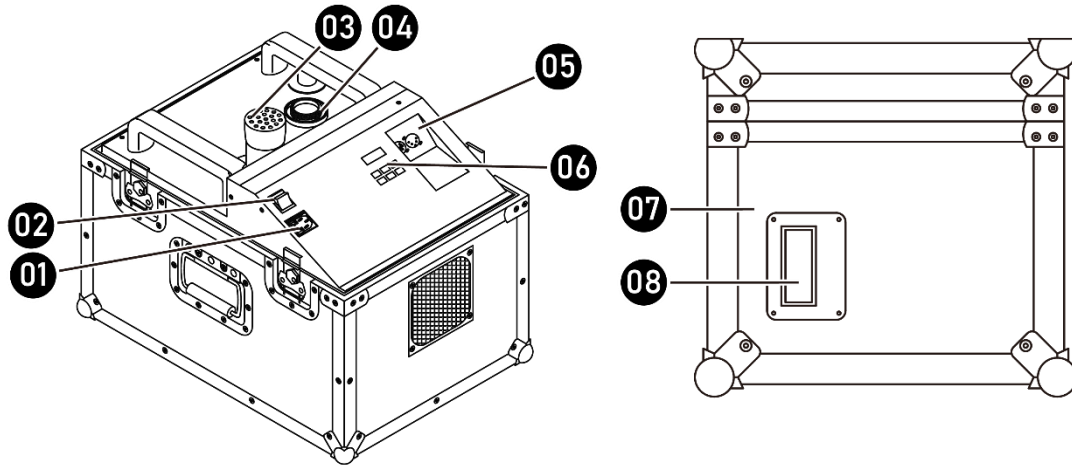

01. IEC 電源連接頭	05. XLR 5-Pin 連接頭 DMX
02. 電源開關	06. 數位控制面板
03. 出煙口/煙霧水倒入口	07. 飛行箱
04. 密封蓋	08. 油量顯示

5. 技術標籤資訊

使用本機器前，請詳閱技術標籤上的訊息

1. 機器型號	5. 斷路器/保險絲
2. 工作電壓	6. 說明書 QR CODE
3. 頻率	7. 機器流水序號
4. 瓦特數	

6. 煙霧水

	危險	將液體加入機器之前，請務必先拔除電源線。請勿添加易燃液體。如果發現液體流入機器內部，請洽 Antari 原廠或其經銷商尋求協助。
--	-----------	--

- 僅能使用 Antari 原廠製造之煙霧水，不可混用或稀釋。若因保存不當而變質或使用非原廠煙霧水，將可能造成機器故障。
- 本機器是使用專屬的煙霧水做測試與校正來取得最佳的效能。
- 如需更換另一種液體，請在使用前，先將油桶中的液體清空，以避免混合。
- 如果使用非原廠製造之煙霧水而導致煙霧機損壞將不在保固範圍內。

7. 設定與手動操作說明



警告

機台掉落可能會造成嚴重傷害，請確保本機台安裝牢固且不會掉落。

- 步驟1.** 將機器平放在堅固、平坦、穩定且通風良好的表面上，機器周圍至少應保留 50 公分的空間並確認附近沒有易燃性物質或可揮發性氣體；
- 步驟2.** 使用 ANTARI 原廠專用煙霧水注入機器；
- 步驟3.** 將機器連接電源，連接之前，確認機器背後技術標籤上所標示要求功率，是否與電源插座相符；
- 步驟4.** 啟動機器電源後，確認紅色指示燈有亮起，當機器已經準備好可進行操作時，螢幕會顯示“Ready to Haze”；
- 步驟5.** 欲開始噴煙，按著[MANUAL]鍵；停止噴煙，放開[MANUAL]鍵；
- 步驟6.** 欲開始噴煙，按一下[VOLUME]鍵；停止噴煙，再按一下[VOLUME]，欲開始噴煙，按一下[TIMER]鍵；停止噴煙，再按一下[TIMER]鍵；這會按照設定的“間隔時間”&“持續時間”來運轉；
- 步驟7.** 需關閉本機時，請確認機器已停止運轉，再將電源開關關閉即可，長時間不使用時請移除電源線。

8. 控制設定





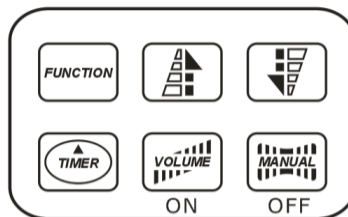

HZ-500 薄霧型特效煙機可以使用下列操作模式，機器每次接受一種訊號。當同時使用多種訊號時機器將根據原廠內建訊號的優先順序來進行工作：

- 手動控制
- 定時控制
- DMX512

8.1 控制面板說明



HZ-500 薄霧型特效煙機可以使用機器上的數位控制面板來操作。

按鈕	操作方式	動作
 Menu	按	進入設置選單
 Up	按	增加數值
 Down	按	減少數值
 TIMER	按	1. 按一下根據設定時間啟動噴煙 2. 按一下”停止”停止噴煙
 ON	按	1. 按一下啟動噴煙 2. 按一下”停止”停止噴煙
 OFF Stop	按	1. 按一下確認設定 2. 離開設置選單 3. 停止噴煙

8.2 選單說明

選單	敘述
Interval Set (間隔設定)	設定間隔時間 1 – 200 秒
Duration Set (持續時間設定)	設定輸出時間 1 – 200 秒
DMX512 Add.	001 - 512
DOOR SENSOR (門蓋偵測器)	開啟 / 關閉 (註 1)
DIRECT HAZE (直接噴煙)	開啟 / 關閉 (註 2)

註 1: 當機器啟動 DOOR SENSOR 模式時，如果出煙口門蓋未確實打開，機器發會出警報聲，螢幕會閃爍並顯示”DOOR CLOSED”及停止噴煙，等到出煙口門蓋確實打開後，才會恢復正常功能。

註 2: 當機器在”直接噴煙”模式時，開啟電源後機器就會開始噴煙，按一下[MANUAL]停止噴煙。

註 3: 當螢幕顯示”Out Of Order”，表示機器內部溫度過高，機器自動開啟保護裝置，無法運作。如果發生此情形，請確認以下兩點排除狀況；

1. 機器後方的風扇濾網是否有清潔，如果有灰塵或異物將會影響散熱。
2. 機器安裝場所周遭是否溫度太高，如果是請將機器移至通風良好的陰涼處。

9. DMX 說明

9.1 接點說明

本機器提供一個 XLR 5-Pin 的 DMX 連接頭。PIN 的接點說明如下：

Pin	功能
1	接地
2	數據-
3	數據+
4	NA
5	NA

**DMX IN 連接頭上有一個保護蓋，操作前，請用手指撥開即可將其取下。

9.2 DMX 通道功能

本機器提供一種 DMX 通道模式可供選擇，請參考下方表單。

DMX 數值範圍	功能
0~250	關閉
251~255	開啟

10. 維護和保養

 危險	維修保養之前，請務必拔除電源線！
---	------------------

- 隨時保持機器清潔及乾燥。
- 可以使用空氣壓縮機、吸塵器或軟刷除去機器上的灰塵。

- 機殼可使用濕布擦拭。
- 儲藏前或使用完畢後，請將液體清空並保持乾燥。
- 建議每月至少讓機器運轉一次，以保持機器處於最佳的性能和輸出條件。
- 機器上過多的灰塵、液體殘餘累積的髒污會降低機器工作性能，導至散熱不良。

11. 技術規格

HZ-500	
電壓	美規 : AC 100-120V, 50/60Hz 3.5A 歐規 : AC 220-240V, 50/60Hz 2.0A
額定功率	120V 400 瓦 240V 480 瓦
耗油量	1.1 毫升/分鐘 (100%輸出)
油桶容量	2.5 公升(0.66 加侖)
適用煙霧水	Antari HZL 特效煙霧水、Antari HZL-W 特效煙霧水
運作時間	37 小時 (100%輸出)
適用環境溫度	0°C – 40°C (32°F – 104°F)
控制方式	手動控制、定時控制、DMX 512
連接座	XLR 5-Pin 連接頭(DMX)、IEC 連接頭(主電源)
DMX 512 通道	1 個頻道
隨附配件	N/A
選購配件	N/A
尺寸	長 515 寬 375 高 355 公釐 (長 20.28 寬 14.77 高 13.98 英寸)
重量	31.5 公斤 (69.45 磅)

12. 保固聲明

本公司保證我們的商品在一年內沒有材料和製作缺陷。我們在本保證下的義務和責任僅限於在原廠或當地授權經銷商進行的維修或更換。我們對不當使用或用於非專門設計目的以外之用途不承擔任何責任。本保固不適用於以任何方式在原廠或當地授權經銷商外修理、改動或組裝的任何商品，以便我們判斷影響其性能，沒有受到誤用、疏忽或事故的影響，也沒有違反我們的任何商品操作印刷說明。本公司對於從我們這邊購買的商品不會允許也不對於使用、銷售或修理任何產品有關的任何類型的任何損失或損害承擔責任。

13. 機器尺寸圖

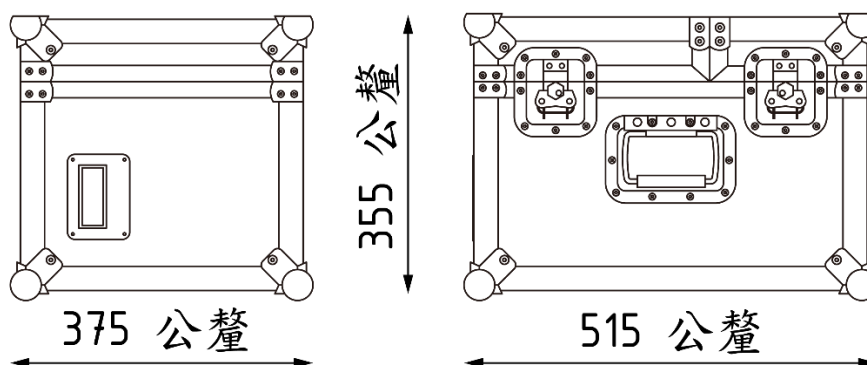

Appendix I Grounding Instruction

This appliance must be grounded. In the event of malfunction or breakdown, grounding provides a path of least resistance for electric current to reduce the risk of electric shock. This appliance is equipped with a cord having an equipment-grounding conductor and a grounding plug. The plug must be plugged into an appropriate outlet that is properly installed and grounded in accordance with all local codes and ordinances.

DANGER – Improper connection of the equipment-grounding conductor can result in a risk of electric shock. The conductor with insulation having an outer surface that is green with or without yellow stripes is the equipment-grounding conductor. If repair or replacement of the cord or plug is necessary, do not connect the equipment-grounding conductor to a live terminal. Check with a qualified electrician or serviceman if the grounding instructions are not completely understood, or if in doubt as to whether the appliance is properly grounded. Do not modify the plug provided with the appliance – if it will not fit the outlet, have a proper outlet installed by a qualified electrician.

This appliance is for use on a nominal 120 V circuit, and has a grounding plug that looks like the plug illustrated in sketch A in Figure. A temporary adaptor, which looks like the adaptor illustrated in sketches B and C, may be used to connect this plug to a 2-pole receptacle as shown in sketch B if a properly grounded outlet is not available. The temporary adaptor should be used only until a properly grounded outlet can be installed by a qualified electrician. The green colored rigid ear, lug, and the like, extending from the adaptor must be connected to a permanent ground such as a properly grounded outlet box cover. Whenever the adaptor is used, it must be held in place by the metal screw.

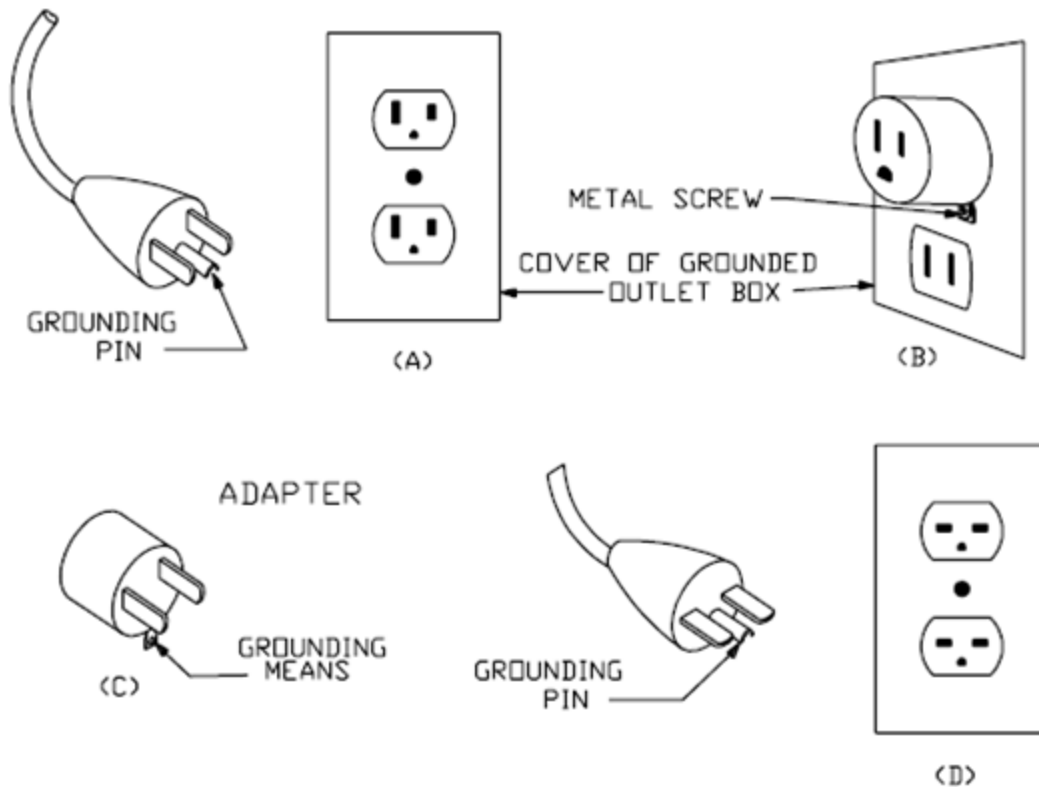



C08HZ5006