

# AVYRA

USER GUIDE



Floorstand 633  
Bookshelf 622  
Center C5



## Index

Warnings	4
Assembly	5
Connecting the Avyra to your equipment	10
Choosing the right amplification	11
Break-in period	11
Set up	12
Spike adjustments	12
Speaker positioning	12
Caring for the Avyra	16
Warranty	16
Specifications	17

We sincerely thank you for choosing MOREL for your home.

Over four decades of innovation and handmade craftsmanship are the core of every speaker we manufacture. The AVYRA Series is a labor of love and unparalleled passion that pushes design and acoustic boundaries to create a speaker that will unleash the raw emotions in music.

Every AVYRA speaker is built with great attention to detail to meet the demands and expectations of the most discerning listeners. We urge you to read the manual and consider our guidance in order to achieve optimal performance. It is always recommended to seek the advice of an authorized Morel retailer or contact us directly at [info@morelhifi.com](mailto:info@morelhifi.com) for any questions you may have.

We wish you many years of listening enjoyment.

**UNLEASH THE MUSIC**

## Warnings

---

- 1 . Make sure to read this manual to ensure proper set up and optimal performance.
- 2 . Make sure you place the loudspeaker on a solid and level floor to not compromise the stability of the speaker and to prevent from additional vibration during music play.
- 3 . Please carefully follow connection instructions to avoid permanent damage to the loudspeaker and/or amplifier.
- 4 . Avoid listening to the audio system at high volumes for extended periods of time.
- 5 . Avoid placing electrical cables in close proximity of the loudspeakers. This may introduce electrical noise and affect the loudspeaker performance.
- 6 . Keep the loudspeakers from any heat source or flammable materials to avoid fire or other damage.
- 7 . Never insert any object to the vent openings in the back of the speaker as it may permanently damage the speaker.
- 8 . Never try to repair the speaker yourself. Always contact Morel or an authorized dealer for support.
- 9 . Please follow the care instructions to ensure the integrity of the cabinet and other components of the speaker.
- 10 . Do not use speaker outdoors or in areas of high heat or extreme humidity.

# Assembly

## ① Unpacking



Remove the tape and open the carton

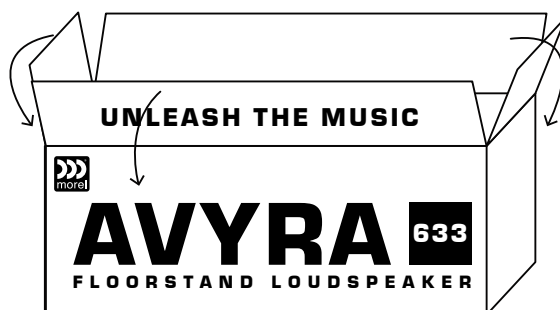

Put the lids on the side

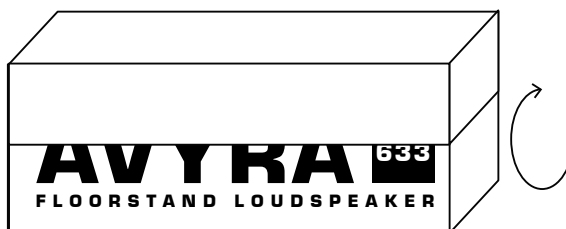

Turn the carton of 180°



Put the lids on the side

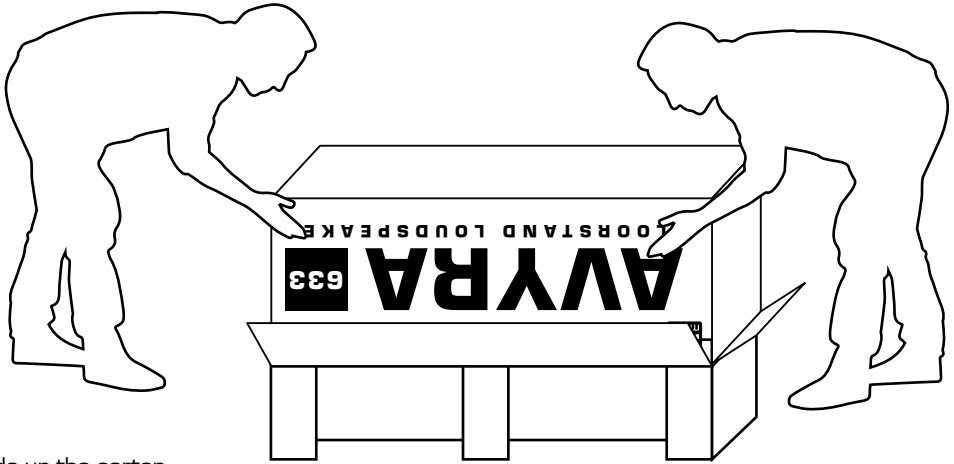

Slide up the carton

- ② Lay down the speaker without removing the foam protectors

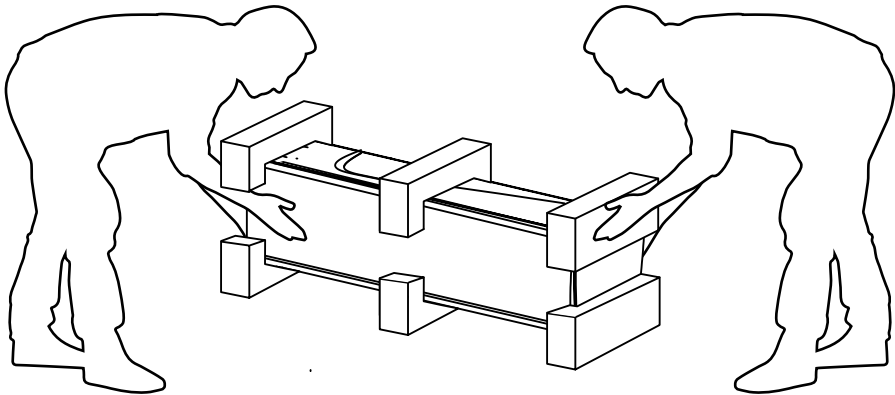

- 3 Slide the middle foam protector to the bottom until it touches the bottom foam protector

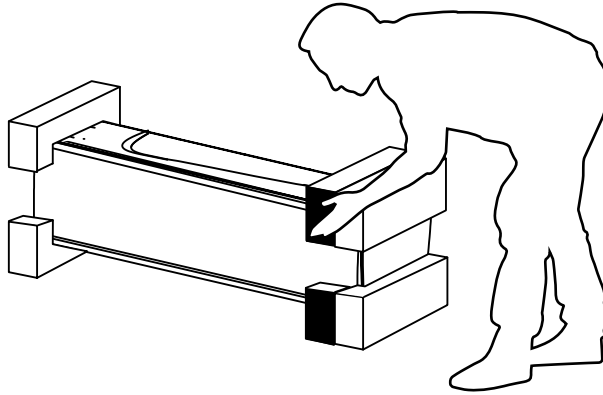
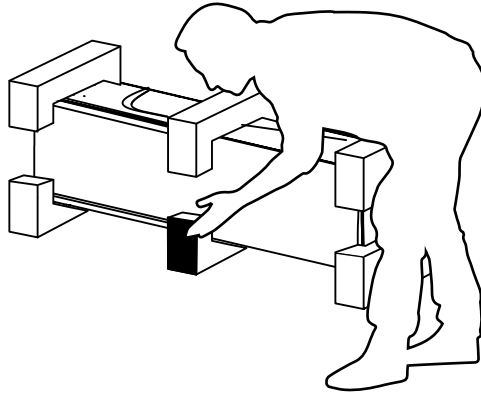

- 4 Remove the bottom foam protector

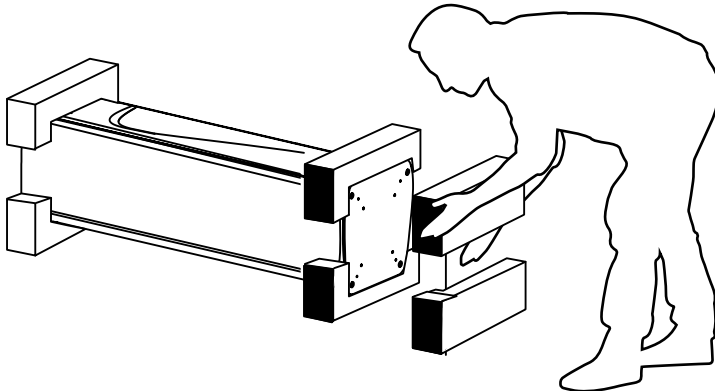

- 5 Screw the spike (clockwise) to the bottom and repeat for the remaining ones

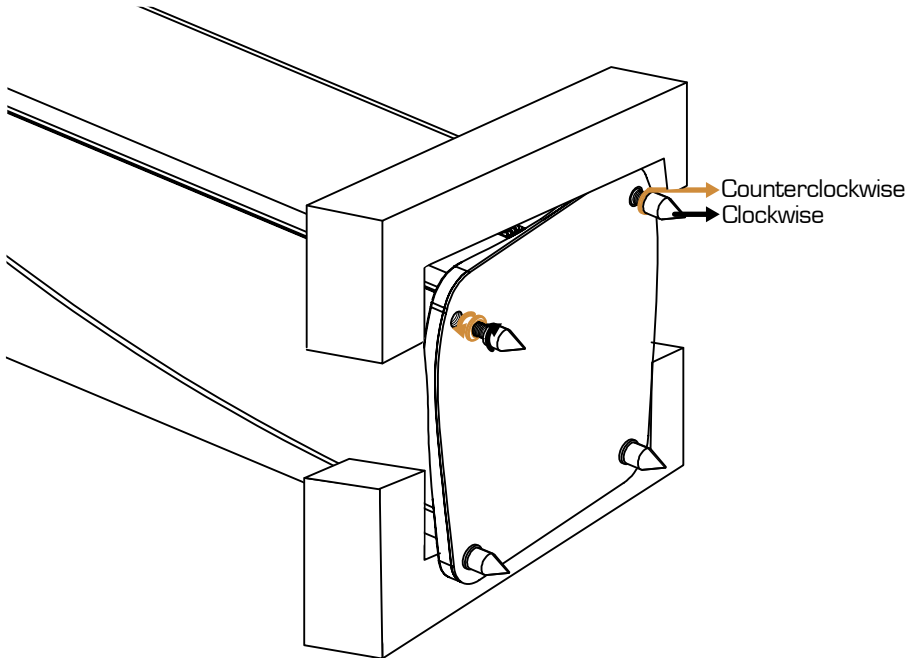

- 6 Remove the middle foam protector

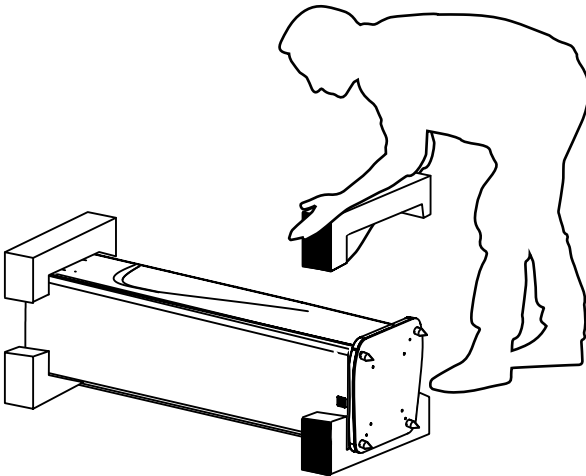

7 Stand the speaker

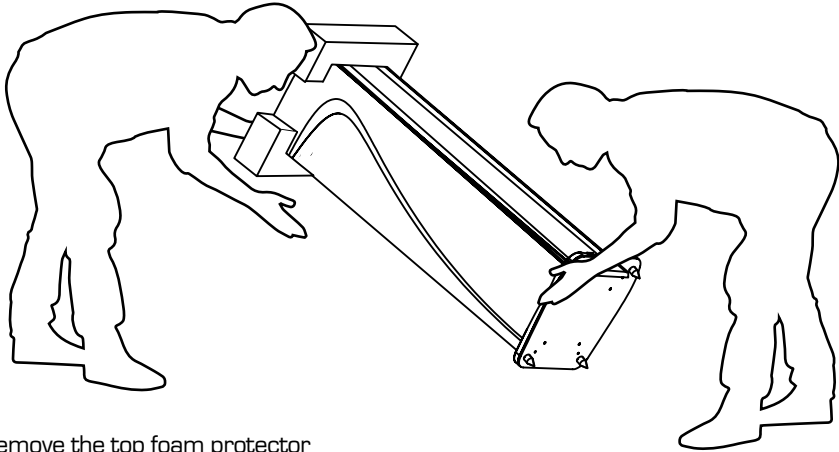

8 Remove the top foam protector

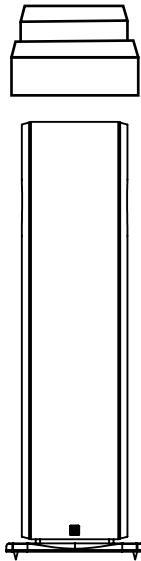

9 Place the floor protector under the spikes

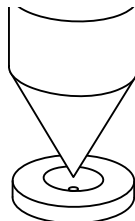

## Connecting the Avyra to your equipment



MAKE SURE ALL EQUIPMENT IS TURNED OFF BEFORE ATTEMPTING TO CONNECT THE SPEAKERS

1. It is critical to ensure that correct polarity is maintained while connecting the speaker to the amplifier. Black (-) and Red (+) terminals on the amplifiers should be connected to the corresponding terminals on the speaker (refer to diagram A).

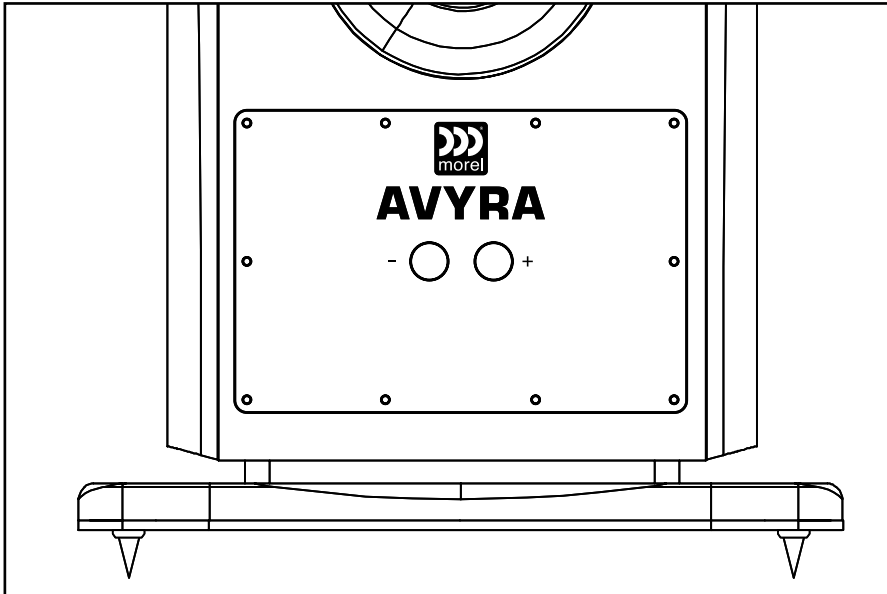

Diagram A

2. The connection terminals of the AVYRA allows for spade connector, banana connector, and up to 5 gauge unsheathed wire (up-hole size is 5mm or smaller) (refer to diagram B).. Make sure you follow local codes and regulations.

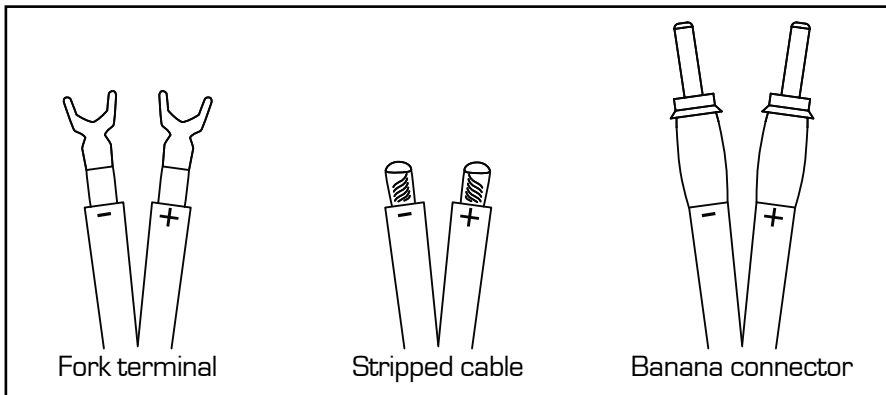
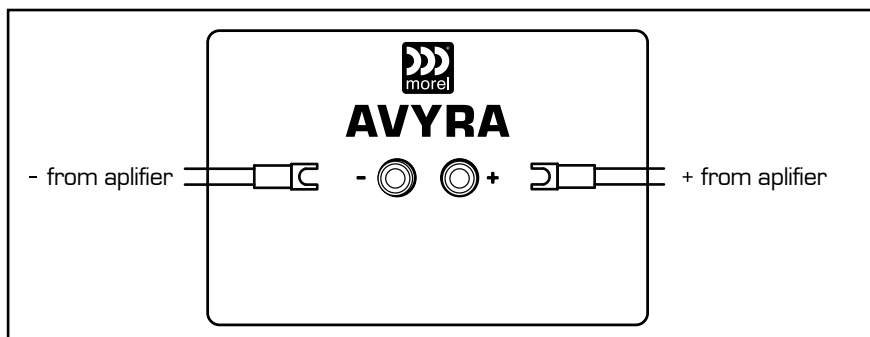

Diagram B

### 3. Connection

The Right speaker needs to be connected to the amplifier's right output terminal and the Left speaker needs to be connected to the amplifier's left output terminal. Refer to Diagram A.



## Choosing the right amplification

---

The Avyra is a very transparent speaker which will mirror the strengths and weakness of any amplifier. It is important to select an amplifier that is power appropriate and, at minimum, matches the RMS power rating of the Avyra. Underpowering your Avyra will be damaging to the dynamics and sound and could lead to product failure.

Note that there are different typologies of amplifiers that have different sound characteristics. Choosing the best amplifier for your needs can be challenging. Morel highly recommends consulting a trusted retailer in the selection process.

## Break-in period

---

As in any high-end speaker system, the Avyra require a break-in period so the drive units can normalize and reach optimum performance. Morel recommends playing the speaker system at incremental volume levels with dynamic audio tracks for 24-36 hours continuously before finalizing the speaker setup. During the break-in period, DO NOT use pink noise, test tones, sine waves or any other generated signal to break-in the speaker as this may be damaging to the speaker and crossover components.

## Set up

---

Before you begin, be aware of objects in the room that may impede the sound from the speakers. When possible, remove or relocate these items prior to setup.

Every living space has different acoustic properties. These characteristic properties are determined by the size and shape of the room, reflective and absorbing materials, and openings (doors/windows), and will have an affect how the speaker will perform.

While there are no absolute rules that pertain to every set up, we do recommend applying the following fundamental guidelines to assist in achieving optimal performance. To do so you will need a distance measuring device, tape, level, pen, calculator, and a lot of patience. Be sure to also bring along your favorite music.

## Spikes Adjustment: Floorstand and Bookshelf stand

---

The Avyra is equipped with metal spikes to offer good stability and acoustic separation from the floor. It is critical to ensure that the loudspeakers are leveled and the tweeters are an equal distance to the floor. To properly adjust, use a tape measure (for the tweeter height) and a level. Once the spikes are adjusted, make sure to lock them in place by tightening the locking nuts.

## Speaker Positioning: Stereo set up

---

- ① Measure the width of the room and divide in half. Mark this position at the base of the wall with a piece of tape. From the tape, measure the distance to the side wall and divide by 10. Starting at the center of the room, initial placement of the speakers will be at positions 5, left and right of center (see diagram D). Now space each speaker a minimum of 50cm (20 inches) away from wall directly behind the speakers.
- ② Set your listening position by creating an isosceles triangle between the speakers and the listening position. It is recommended that the distance between the two speakers (B) be greater than  $2/3$  of the distance to the listening position (A). (Refer to diagram D)

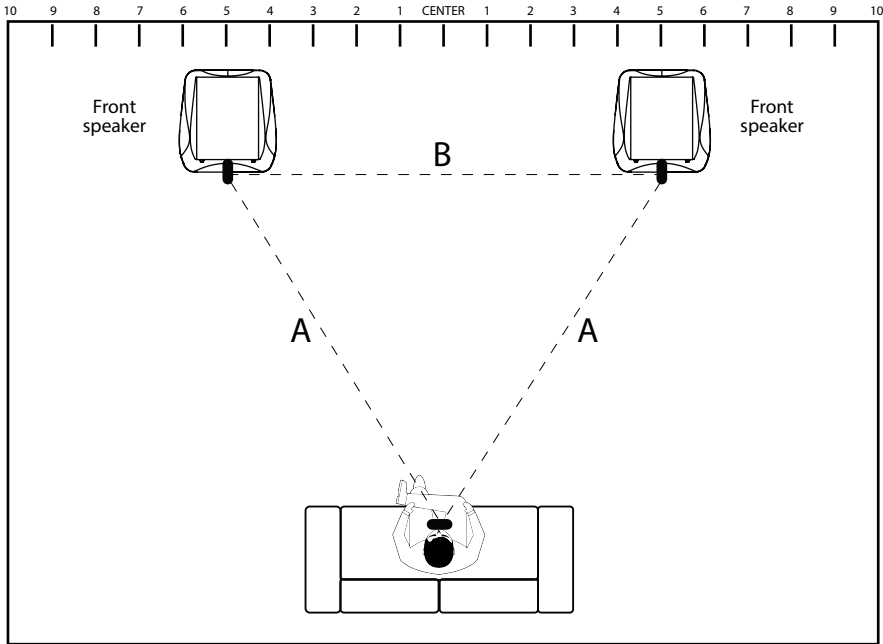

Diagram D

- 3 Positioning of the speaker affects the bass level performance. As a general guidance, placing the speaker closer to the back and/or side walls will increase the bass notes by up to 6dB due to the loading effect created by the proximity to the walls [refer to Diagram E].

The bass can be adjusted by changing the distance between the speaker and the back and/or side wall. Select a jazz track with double bass or repetitive bass line and move the speakers closer to the listening position in 10CM (4-inch) increments until the bass performance sounds balanced. If the bass sounds too big or boomy, the speakers need to be moved forward. If the bass is too lean, move the speakers toward the wall.

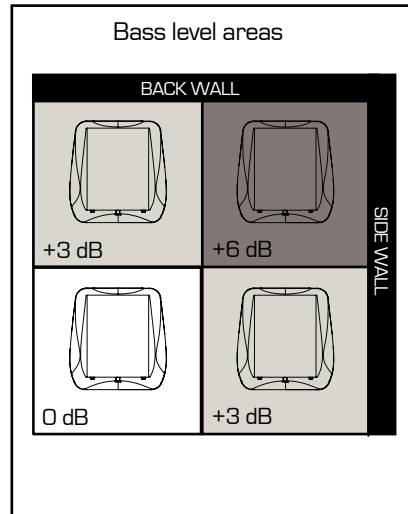

Diagram E

- ④ Soundstage and imaging are affected by the distance between the speakers and their toe-in position. The balance between the two is critical. Start by listening to the speakers in their initial position (step 1) and then move the speakers outward to position 6, and then inward to 4, etc., while maintaining a stationary listening position. Listen to the speakers after each adjustment until the instruments and vocals are balanced across the soundstage. Use tape to mark each position.
- ⑤ Using a vocal track, toe-in the speakers to adjust the sound stage and imaging until it becomes focused with instruments and vocals easily distinguished and precisely positioned. It is extremely important that the speakers are adjusted in a symmetrical manner. Using the inner front spike of each speaker as a reference, pivot the speakers in small increments towards the listener's position until the image is stable and the depth of the soundstage is even. If done correctly, the physical speakers should disappear and no sound should localize to the location of the speaker itself. (Please refer to diagram F).

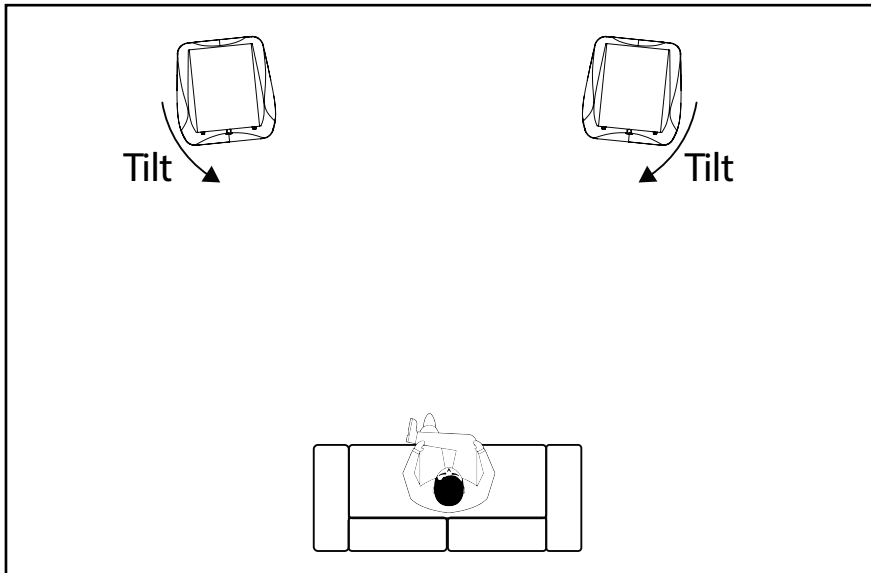

Diagram F

## Speaker Positioning: Home theater

- 1 Follow the Stereo set up positioning.
- 2 Place the center channel speaker: the center channel speaker is typically positioned above or below the TV or projection screen. It should be centered and directly facing the primary listening position. If the speaker has an adjustable angle, aim it towards the listener's ear level (refer to Diagram G).

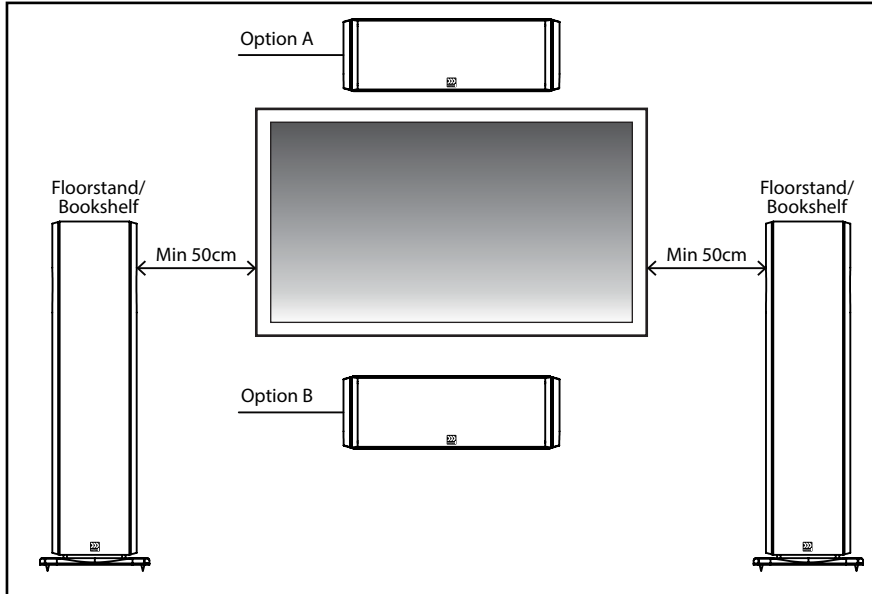

Diagram G

- 3 Set up the surround speakers: If you have surround speakers (e.g., in a 5.1 or 7.1 setup), position them to the sides or slightly behind the primary listening area. They should be at an equal distance from the center channel speaker and angled towards the listener (refer to Diagram H).

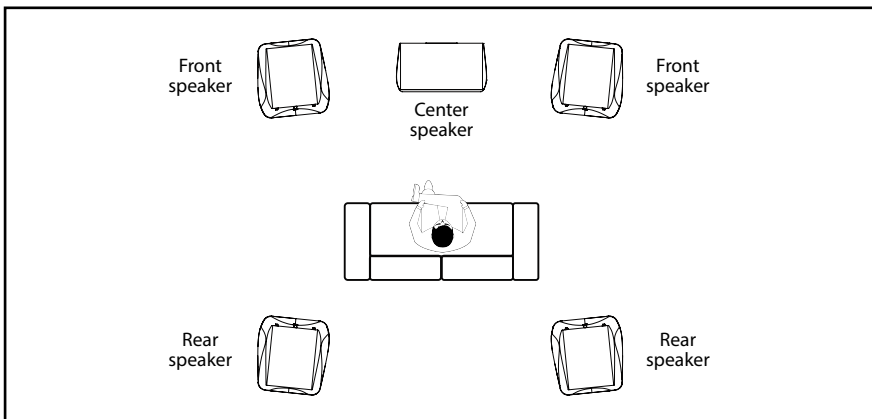

Diagram H

- 4 Place the subwoofer: the subwoofer, responsible for low-frequency sounds, can be positioned anywhere in the room. Experiment with different locations to find the spot that delivers the best bass response. Common positions include the front of the room, a corner, or near the front speakers.  
If the subwoofer is in front of the room the phase is  $0^\circ$ , if the subwoofer is in the rear of the room the phase is  $180^\circ$ .

## Caring for the AVYRA

---

Morel manufactured the AVYRA using premium raw materials so it would last for many years with minimal maintenance requirements.

Morel recommends wiping down the cabinet periodically using only a microfiber cloth. **DO NOT USE** any detergents, waxes, alcohol or other chemicals to clean the speaker as it may damage the finish. The delicate drivers should only be cleaned as required with a very soft brush and a gentle hand, and never with any liquid.

Avoiding placing the speaker under direct sunlight or next to a high heat source or in areas of extreme humidity as this will impact the integrity of the paint and cabinet.

## Warranty

---

All Morel speakers are guaranteed to be free of manufacturing defects.

We implement stringent quality control protocols to ensure that each speaker meets the highest standards. We highly suggest registering your speaker on our website to receive the latest news from Morel and authenticate your warranty.

Please contact your local dealer for more detailed warranty guidelines.

## Specifications: Floorstand

---

Type	2.5-way 3 drive unit system
Construction	Medium Density Fiber enclosure with black/white/wood finish
Acoustical Loading	Bass reflex
Drive Units	Woofer: 2 x 6" (160 mm) with integrated one piece cone, double magnet motor, 3" (75 mm) EVC™ (External Voice Coil) aluminium voice coil.  Tweeter: 1.1" (28mm) Acuflex™ handcrafted soft dome, aluminium voice coil.
Frequency Response	25-20,000 Hz (+2dB - 4dB)
Nominal Impedance	4 ohm
Nominal Power Handling	200 W
Peak Power Handling	1000W
Sensitivity 2.83V/1 M	89 dB
Crossover	250 Hz / 2.2 kHz
Dimension (W x H x D)	12.2" X 38.6" X 12.8" (310mm X 982mm X 326mm )
Weight	22 KG

## Specifications: Bookshelf

---

Type	2-way 2 drive unit system
Construction	Medium Density Fiber enclosure with black/white/wood finish
Acoustical Loading	Bass reflex
Drive Units	<p>Woofer: 1 x 6" (160 mm) with integrated one piece cone, double magnet motor, 3" (75 mm) EVC™ (External Voice Coil) aluminium voice coil, Titanium Bobbin.</p> <p>Tweeter: 1.1" (28mm) Acuflex™ handcrafted soft dome, aluminium voice coil.</p>
Frequency Response	35-20,000 Hz (+2dB -3dB)
Nominal Impedance	4 ohm
Nominal Power Handling	160 W
Peak Power Handling	1000W
Sensitivity 2.83V/1 M	88.0 dB
Crossover	2.2 kHz
Dimension (W x H x D)	9.5" X 14.2" X 10.6" (241mm X 360mm X 271mm )
Weight	8 KG

## Specifications: Center

---

Type	2-way 3 drive unit system
Construction	Medium Density Fiber enclosure with black/white/wood finish
Acoustical Loading	Bass reflex
Drive Units	<p>Woofer: 2 x 5" (127 mm) . cone type with integrated one piece cone, neodymium double magnet motor, 3" (75 mm) EVC™ (External Voice Coil) aluminium voice coil.</p> <p>Tweeter: 1.1" (28mm) Acuflex™ handcrafted soft dome, neodymium magnet motor, aluminium voice coil.</p>
Frequency Response	45-20,000 Hz (+2dB -4dB)
Nominal Impedance	4 ohm
Nominal Power Handling	180 W
Peak Power Handling	1000W
Sensitivity 2.83V/1 M	89dB
Crossover	2.2 kHz
Dimension (W x H x D)	19.9" X 6.6" X 10.7" (506mm X 169mm X 272mm )
Weight	8 KG



Morel, Ness Ziona, 70400 Israel.  
Tel: +972-8-9301161  
Fax: +972-8-9301312  
E-mail: [info@morelhifi.com](mailto:info@morelhifi.com)

Morel America, Chandler, AZ, USA  
Toll free number: 1-877-667-3511  
Fax: 1-718-721-1560  
E-mail: [info@morelamerica.com](mailto:info@morelamerica.com)

[www.morelhifi.com](http://www.morelhifi.com)