

SRX800 S E R I E S



USER'S GUIDE

SRX812P

SRX815P

SRX835P

SRX818SP

SRX828SP



CONTENTS

Safety Instructions	4
Declaration Of Conformity	5
Quick Setup Guide	6
SRX812P, SRX815P, SRX835P Back Panel	8
SRX828SP, SRX818SP Back Panel	10
Overview - SRX800 Family	12
SRX812P, SRX815P - Block Diagram	13
SRX835P - Block Diagram	14
SRX818SP - Block Diagram	15
SRX828SP - Block Diagram	16
SRX812P Specifications	17
SRX815P Specifications	18
SRX835P Specifications	19
SRX818SP Specifications	20
SRX828SP Specifications	21
Purposeful Product Design	22
Component Elements	23
Back Panel LCD	25
SRX Presets	27
Premium DSP Technology	29
Networking	30
Smart Device App	32
Loudspeaker Placement and Suspension	33
TroubleShooting	34
Warranty Information	35
Contact Information	36

SAFETY INSTRUCTIONS

Before You Begin - Important Safety Information

Before using your SRX800® speaker system please review the following for important information on safety and protection of your investment in quality loudspeakers.

1. Read these instructions.
2. Keep these instructions.
3. Follow all instructions.
4. Heed all warnings.
5. Do not use this apparatus near water.
6. Clean only with dry cloth.
7. Do not block any ventilation openings. Install in accordance with the manufacturer's instructions.
8. Do not install near any heat sources such as radiators, heat registers, stoves, or other apparatus (including amplifiers) that produce heat.
9. Do not defeat the safety purpose of the polarized or grounding-type plug. A polarized plug has two blades with one wider than the other. A grounding-type plug has two blades and a third grounding prong. The wide blade or the third prong is provided for your safety. If the provided plug does not fit into your outlet, consult an electrician for replacement of the obsolete outlet.
10. Protect the power cord from being walked on or pinched, particularly at plugs, convenience receptacles, and the point where they exit from the apparatus.
11. Only use attachments/accessories specified by the manufacturer.
12. Use only with the cart, stand, tripod, bracket, or table specified by the manufacturer, or sold with the apparatus. When a cart is used, use caution when moving the cart/apparatus combination to avoid injury from tip-over.
13. Unplug this apparatus during lightning storms or when unused for long periods of time.
14. Refer all servicing to qualified service personnel. Servicing is required when the apparatus has been damaged in any way, such as power supply cord or plug is damaged, liquid has been spilled or objects have fallen into the apparatus, the apparatus has been exposed to rain or moisture, does not operate normally, or has been dropped.
15. CAUTION - DO NOT PERFORM ANY SERVICING UNLESS YOU ARE QUALIFIED TO DO SO.
16. To completely disconnect this apparatus from the AC mains, disconnect the power supply cord plug from the AC receptacle.
17. WARNING – TO REDUCE THE RISK OF FIRE OR ELECTRIC – SHOCK, DO NOT EXPOSE THIS APPARATUS TO RAIN OR MOISTURE.
18. Do not expose this equipment to dripping or splashing and ensure that no objects filled with liquids, such as vases, are placed on the equipment.
19. THE MAINS PLUG OF THE POWER SUPPLY CORD SHALL REMAIN READILY OPERABLE.



DECLARATION OF CONFORMITY

Safety And EMC Compliance Specifications

Report No.	Description
EN 55103-1:2009 +A1:2012	EMC Compatibility – Product Family Standard for Audio, Video, Audio-Visual and Entertainment Lighting Control Apparatus for Professional Use, Part 1: Emissions
EN 55103-1:2009 +A1:2012	Magnetic Field Emissions – Annex A @ 10cm and 20cm
EN 61000-3-2:2006 +A1:2008 +A2:2009	Limits for Harmonic Current Emissions (equipment input current less than or equal to 16A
EN 61000-3-3:2013	Limitation of Voltage Fluctuations and Flicker in Low-Voltage Supply systems Rated Current less than or equal to 16A
EN 55022:2010	Limits and Methods of Measurement of Radio Disturbance Characteristics of ITE: Radiated, Class B Limits; Conducted, Class A
EN 55103-2:2009	EMC Compatibility – Product Family Standard for Audio, Video, Audio-Visual and Entertainment Lighting Control Apparatus for Professional Use, Part 2: Immunity
EN 61000-4-2:2008 Ed 2.0	Electrostatic Discharge Immunity (Environment E2-Criteria B, 4k V Contact, 8k V Air Discharge)
EN 61000-4-3:2010 Ed 3.2	Radiated, Radio-Frequency, EMC Immunity (Environment E2, Criteria A)
EN 61000-4-4:2007	Electrical Fast Transient/Burst Immunity (Criteria B)
EN 61000-4-5:2006	Surge Immunity (Criteria B)
EN 61000-4-6:2006	Immunity to Conducted Disturbances Induced by Radio-Frequency Fields (Criteria A)
EN 61000-4-11:2004	Voltage Dips, Short Interruptions and Voltage Variation
Safety Standard:	
EN60065:2002 +A12:2011, IEC 60065:2001 Ed 7 +A1:2005 +A2:2010	Safety Requirements – Audio, Video, and Similar Electronic Apparatus
CAN/CSA 60065-03 incl. A1	Safety Requirements – Audio, Video, and Similar Electronic Apparatus
UL Std No. 60065-2007	Safety Requirements – Audio, Video, and Similar Electronic Apparatus

UL Compliance Specifications

UL 60065 7th Ed. CAN/CSA 22.2 No.60065_2003

FCC Statement

1. This device complies with Part 15 of the FCC Rules.

Operation is subject to the following two conditions:

- (1) This device may not cause harmful interference.
- (2) This device must accept any interference received, including interference that may cause undesired operation.

2. Changes or modifications not expressly approved by the party responsible for compliance could void the user's authority to operate the equipment.

NOTE: This equipment has been tested and found to comply with the limits for a Class B digital device, pursuant to Part 15 of the FCC Rules. These limits are designed to provide reasonable protection against harmful interference in a residential installation.

This equipment generates uses and can radiate radio frequency energy and, if not installed and used in accordance with the instructions, may cause harmful interference to radio communications. However, there is no guarantee that interference will not occur in a particular installation. If this equipment does cause harmful interference to radio or television reception, which can be determined by turning the equipment off and on, the user is encouraged to try to correct the interference by one or more of the following measures:

- Reorient or relocate the receiving antenna.
- Increase the separation between the equipment and receiver.
- Connect the equipment into an outlet on a circuit different from that to which the receiver is connected.
- Consult the dealer or an experienced radio/TV technician for help.

FCC Radiation Exposure Statement

This equipment complies with FCC radiation exposure limits set forth for an uncontrolled environment. This equipment should be installed and operated with minimum distance 20cm between the radiator & your body.

IC Warning

1. This device complies with Industry Canada licence-exempt RSS standard(s). Operation is subject to the following two conditions:

- (1) this device may not cause interference, and
- (2) this device must accept any interference, including interference that may cause undesired operation of the device.

2. Changes or modifications not expressly approved by the party responsible for compliance could void the user's authority to operate the equipment.

Le présent appareil est conforme aux CNR d'Industrie Canada applicables aux appareils radio exempts de licence. L'exploitation est autorisée aux deux conditions suivantes :

- (1) l'appareil ne doit pas produire de brouillage, et
- (2) l'utilisateur de l'appareil doit accepter tout brouillage radioélectrique subi, même si le brouillage est susceptible d'en compromettre le fonctionnement."

QUICK SETUP GUIDE

Congratulations on your purchase of JBL Professional SRX800 Series loudspeakers! We know you are anxious to get up and running as fast as possible, which is why you are reading this section. The following will help you get set up as soon as possible.

Packaging Contents

Your SRX800 system should include the following:

- 1 x SRX800 speaker
- 1 x 10'(3m) IEC Power Cable
- 1 x Quick Start Guide

Configuration Options

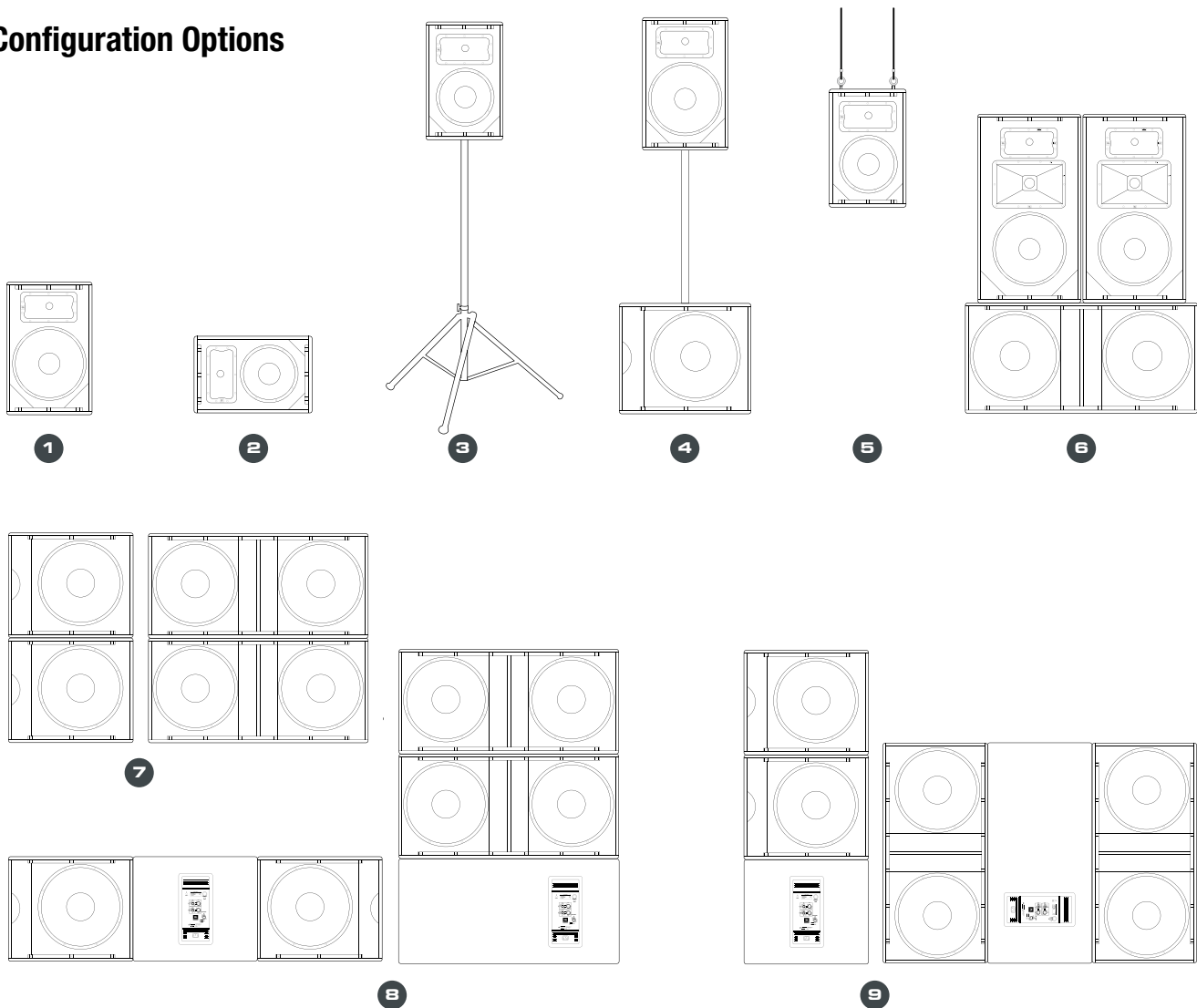

1. Floor Standing
2. Monitor
3. Pole Mounted
4. Sub Mounted
5. Suspended

6. Subs with 3-way splayed
7. Stacked Subs
8. Cardioid Subs
9. Cardioid Subs Vertical

QUICK SETUP GUIDE

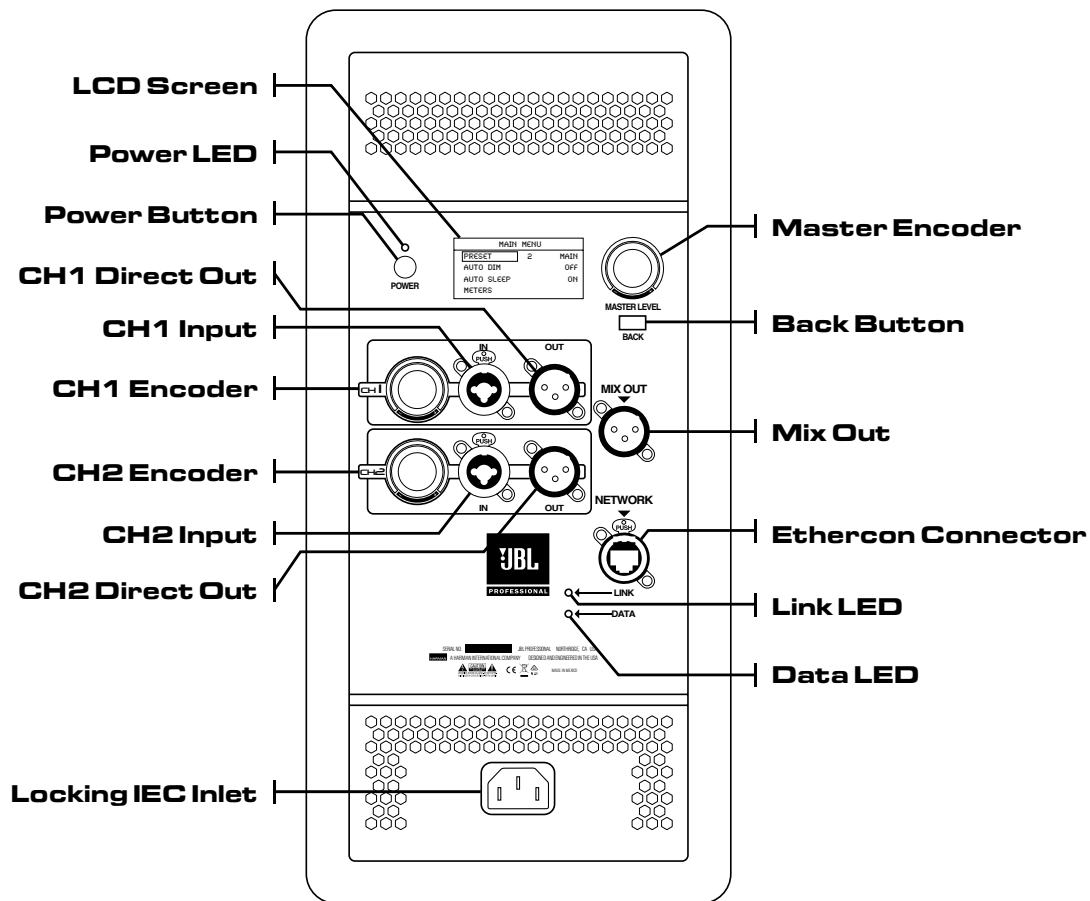

Power it on

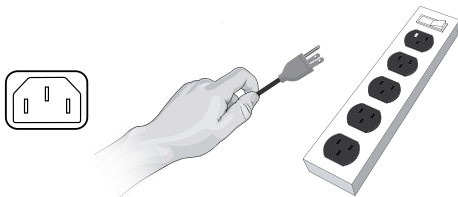

1. Connect the supplied power cord to the Blue IEC inlet on the rear of the speaker
2. Connect the power cord to an available power outlet. Once the power cord is plugged into the power source, the Green Power LED will illuminate.
3. Once the Green Power LED illuminates, press the Power Button. After several seconds, you will notice the LCD Screen boot and you will now be on the main screen.

Plug in the inputs

1. The CH1 and CH2 Input levels and Master Level default to -20dB. It's a good idea to turn the inputs down all the

way before plugging in your audio source. Turn CH1 and/or CH2 Encoders to the left until the level reads "- 100" on the LCD.

2. Connect XLR or TRS cable from audio source to CH1 and/or CH2 Inputs.
3. Select LINE, CONSUMER or MIC gain setting by pushing the correct CHANNEL ENCODER twice. You will see a rectangle highlighting the sensitivity setting. Simply roll the encoder left or right to select the correct setting. Once the correct setting is shown, push the encoder one more time to make your selection.

Set output levels

1. Set the gain level for each input using the CH1 and/or CH2 ENCODER. The input level meter on the LCD will allow you to monitor your input level.
2. Once the input level is set, use the MASTER ENCODER to turn up (Right) or turn down (Left) the overall level until the desired volume is reached.

SRX812P, SRX815P, SRX835P BACK PANEL

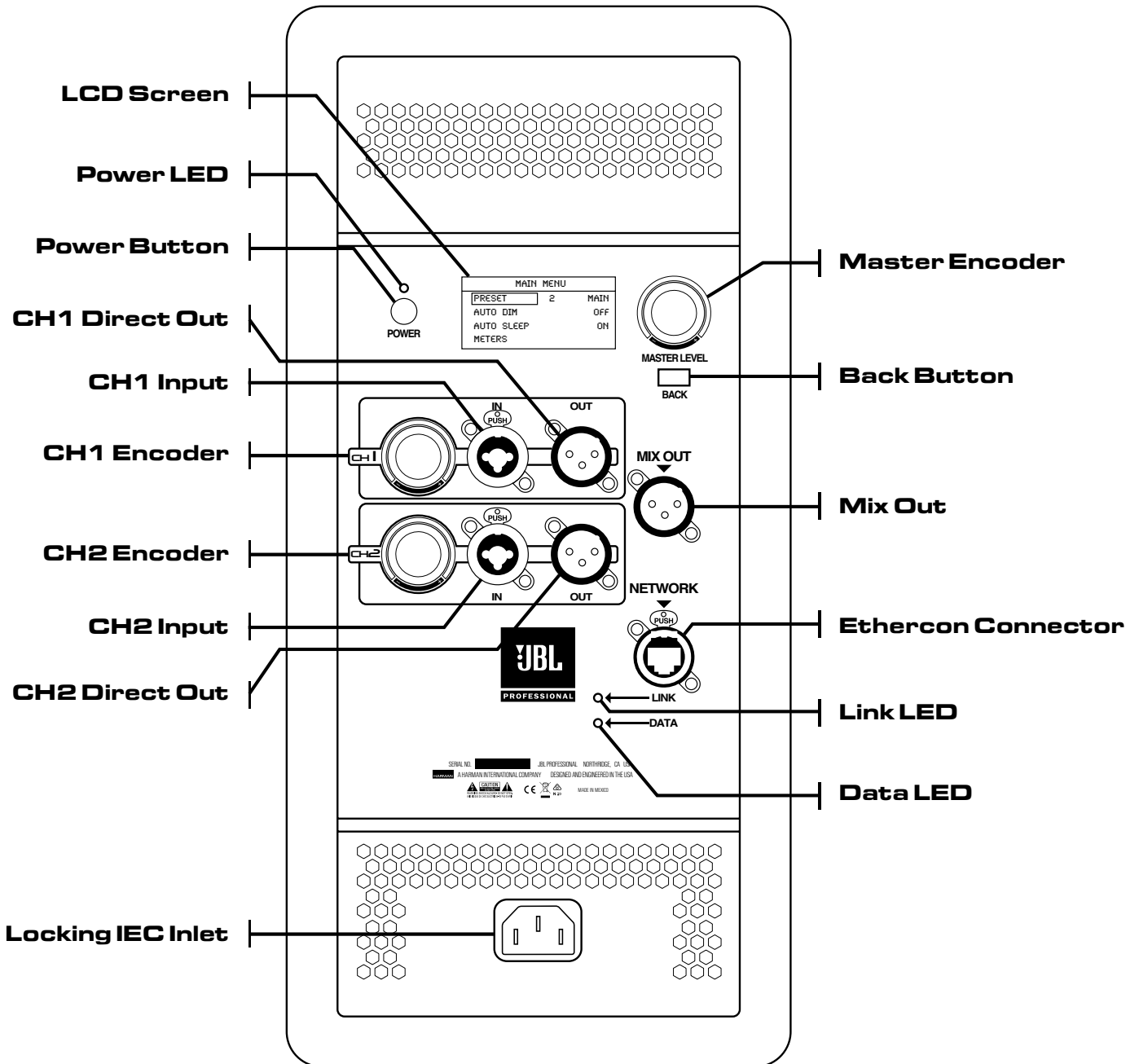

SRX812P, SRX815P, SRX835P BACK PANEL

LCD Screen

Allows users to access presets and basic controls for the system without a network connection. Controlled with the Master Encoder and the Back Button.

Power LED

This LED (Green) lights to indicate that the speaker is plugged in and that power is going to the speaker. .

Power Button

Turns the power on.

CH1 Input

These balanced inputs accepts a standard XLR (female) connector and also a 1/4" TRS phone plug. A broad range of signals from microphones, audio mixing consoles and electronic musical instruments may be connected here.

CH1 Direct Out

Male balanced XLR output connector. Passes signal directly from the input to the output, bypassing DSP for zero latency. This connector provides a full-range signal which can be daisy chained to another speaker.

CH1 Encoder

Controls the gain of CH1. By turning the signal counter-clockwise you will be lowering the gain of your source material. By turning the control clockwise you will be increasing the gain.

CH2 Input

These balanced inputs accepts a standard XLR (female) connector and also a 1/4" TRS phone plug. A broad range of signals from microphones, audio mixing consoles and electronic musical instruments may be connected here.

CH2 Direct Out

Male balanced XLR output connector. Passes signal directly from the input to the output, bypassing DSP for zero latency. This connector provides a full-range signal which can be daisy chained to another speaker.

CH2 Encoder

Controls the gain of CH2. By turning the signal counter-clockwise you will be lowering the gain of your source material. By turning the control clockwise you will be increasing the gain.

Locking IEC Inlet

Standard IEC AC mains input connector.

Master Encoder

Controls the master volume of the unit. By turning the knob counter-clockwise you will be lowering the overall volume of the speaker. By turning the control clockwise you will be increasing the overall volume of the speaker. See page 25 for instructions on using the Master Encoder to control LCD screen.

Back Button

Used in conjunction with the Master Encoder to control the LCD Screen.

Mix Out

This XLR (male) output connector provides a method of sending audio out to an external source. Passes signal based on the input levels of channels 1 and 2 post DSP, adding some latency (approx. 2 milliseconds) to the signal.

Ethercon Connector

Allows network connection with a standard Ethernet cable for networking multiple units and controlling the system. This connector is not to be connected to a LAN line.

Link LED

This LED lights to indicate that the speaker is connected to a network.

Data LED

This LED blinks to indicate that data is being sent and received by the system.

SRX828SP, SRX818SP BACK PANEL

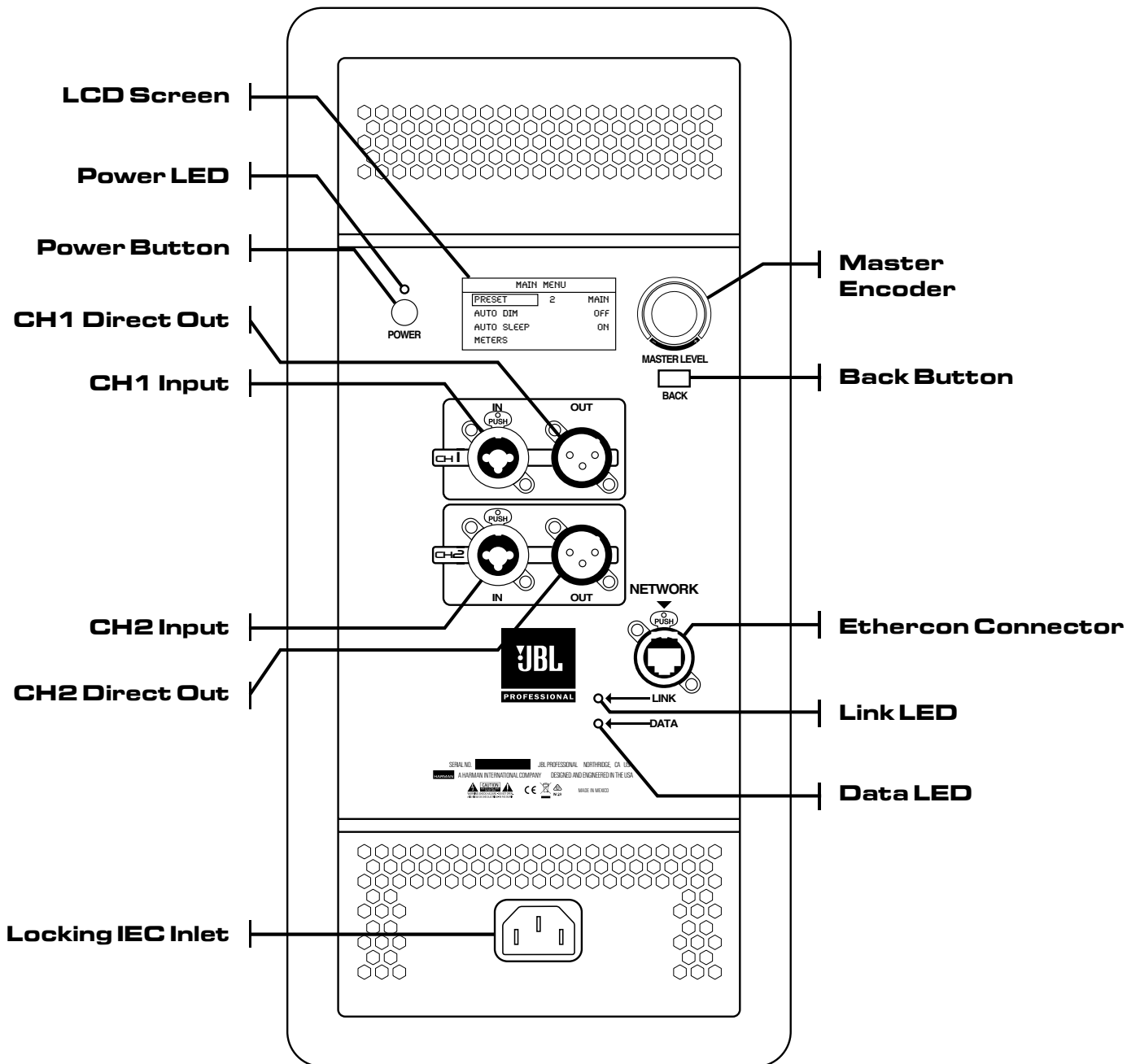

SRX828SP, SRX818SP BACK PANEL

LCD Screen

Allows users to access presets and basic controls for the system without a network connection. Controlled with the Master Encoder and the Back Button.

Power LED

This LED (Green) lights to indicate that the speaker is plugged in and that power is going to the speaker.

Power Button

Turns the power on.

CH1 Input

These balanced inputs accept a standard XLR (female) connector and also a 1/4" TRS phone plug. A broad range of signals from microphones, audio mixing consoles and electronic musical instruments may be connected here.

CH1 Direct Out

Male balanced XLR output connector. Passes signal directly from the input to the output, bypassing DSP for zero latency. This connector provides a full-range signal which can be daisy chained to another speaker.

CH2 Input

These balanced inputs accept a standard XLR (female) connector and also a 1/4" TRS phone plug. A broad range of signals from microphones, audio mixing consoles and electronic musical instruments may be connected here.

CH2 Direct Out

Male balanced XLR output connector. Passes signal directly from the input to the output, bypassing DSP for zero latency. This connector provides a full-range signal which can be daisy chained to another speaker.

Locking IEC Inlet

Standard IEC AC mains input connector.

Master Encoder

Controls the master volume of the unit. By turning the knob counter-clockwise you will be lowering the overall volume of the speaker. By turning the control clockwise you will be increasing the overall volume of the speaker. See page 25 for instructions on using the Master Encoder to control LCD screen.

Back Button

Used in conjunction with the Master Encoder to control the LCD Screen.

Ethercon Connector

Allows network connection with a standard Ethernet cable for networking multiple units and controlling the system. This connector is not to be connected to a LAN line.

Link LED

This LED lights to indicate that the speaker is connected to a network.

Data LED

This LED blinks to indicate that data is being sent and received by the system.

OVERVIEW - SRX800 FAMILY

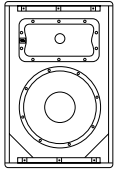

SRX812P

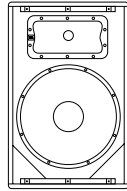

SRX815P

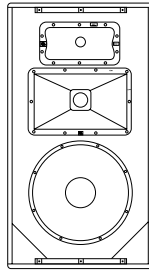

SRX835P

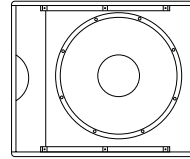

SRX818SP

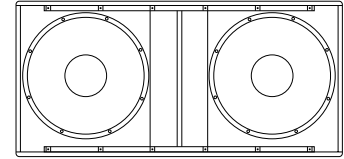

SRX828SP

Thank you for purchasing the new JBL SRX800!

The SRX800 Series is the next generation high performance powered loudspeaker system from JBL Professional. Comprising three full range and two subwoofers, the SRX800 boasts an array of premium features that make it the very best system in its class. Drawing on JBL's long history of groundbreaking technology and innovative loudspeaker design, the SRX800 Series meets the needs of the most demanding applications where high performance, comprehensive control and legendary JBL sound are required. Each component in the SRX800 Series was purposefully designed and thought through with full consideration for its intended use, each component carefully matched to achieve a perfectly tuned system that is both powerful and easy to use.

The full range 12" two-way, 15" two-way and 15" three-way systems are powered by proprietary 2,000 Watt Crown amplification. The 18" subwoofer and 18" dual subwoofer feature 1,000 and 2,000 Watt Crown amplifiers. All models integrate Crown's Proprietary Front-End DriveCore Technology, premium JBL user-configurable DSP, including V5 Tunings compatible with our flagship Vertec and VTX touring systems, and full HiQnet Network control with Mac and PC software and standalone applications for iOS and Android. Now, local touring houses and smaller to medium installations can deploy a no-compromise, all-in-one solution configurable as a full range system with monitors and subs, either floor standing, tripod mounted, stacked, or pole mounted, and fully flyable with the SRX800's integrated suspension points.

SRX812P, SRX815P - BLOCK DIAGRAM

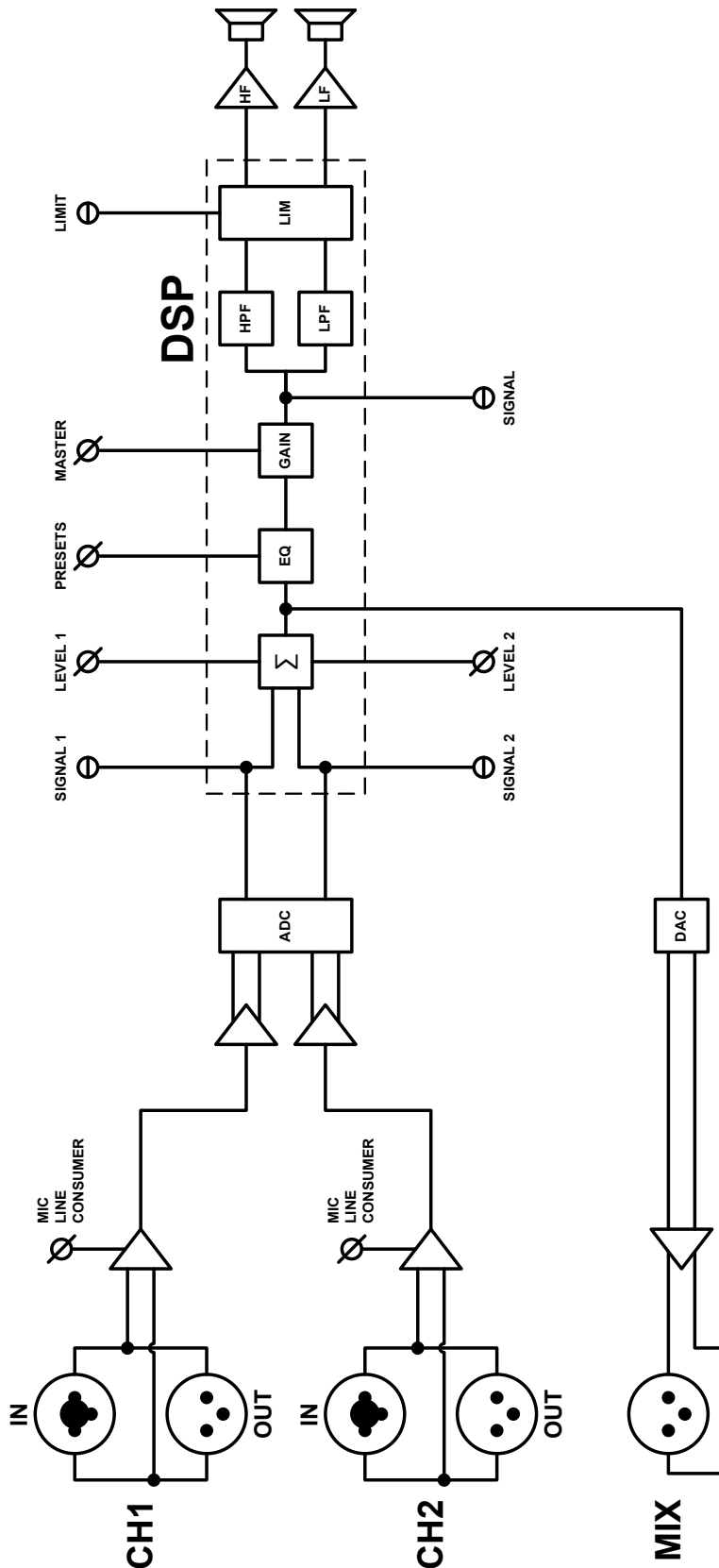

SRX835P - BLOCK DIAGRAM

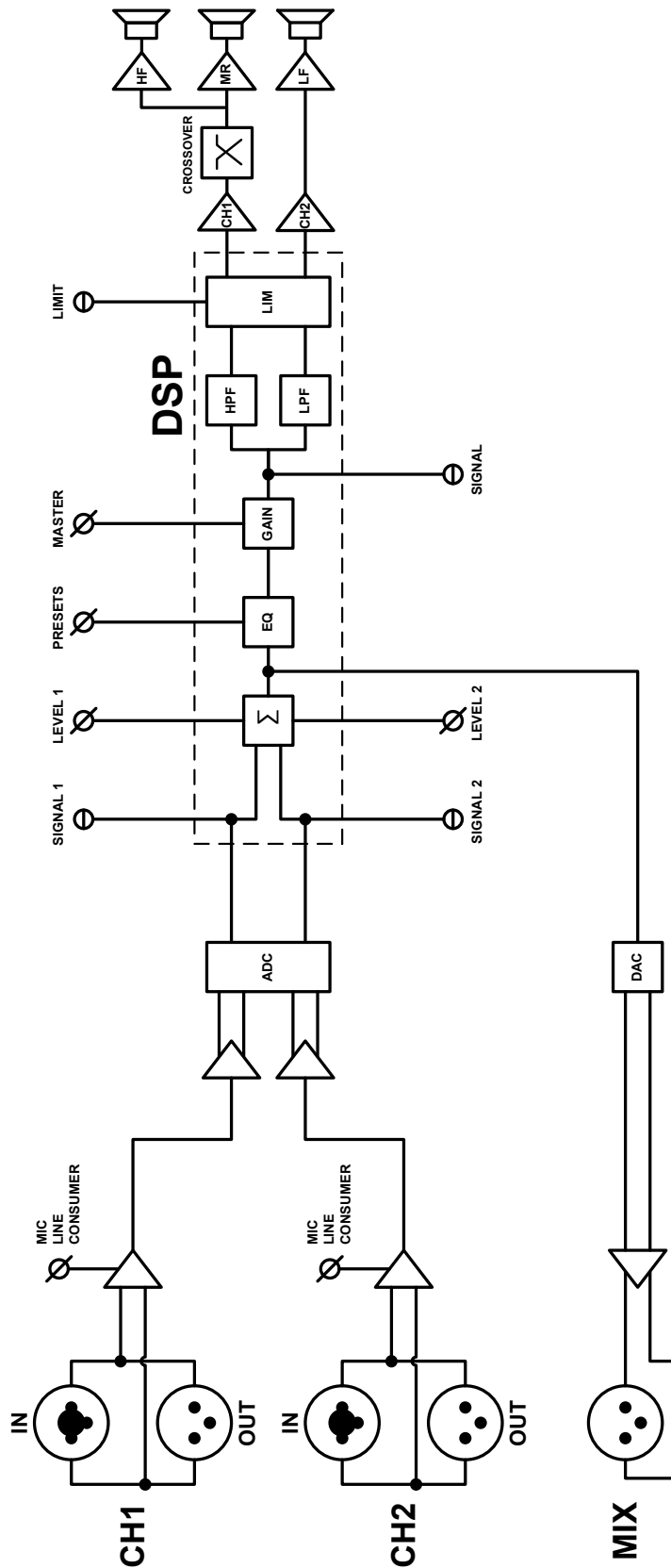

SRX818SP - BLOCK DIAGRAM

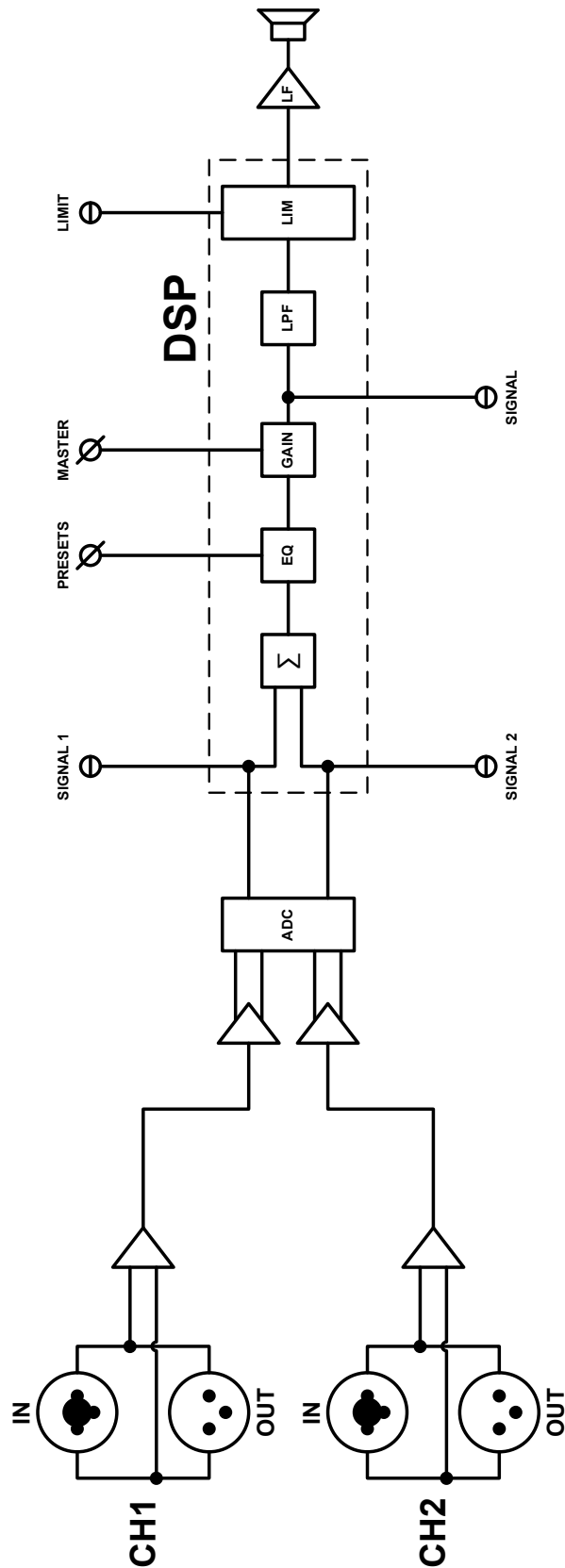

SRX828SP - BLOCK DIAGRAM

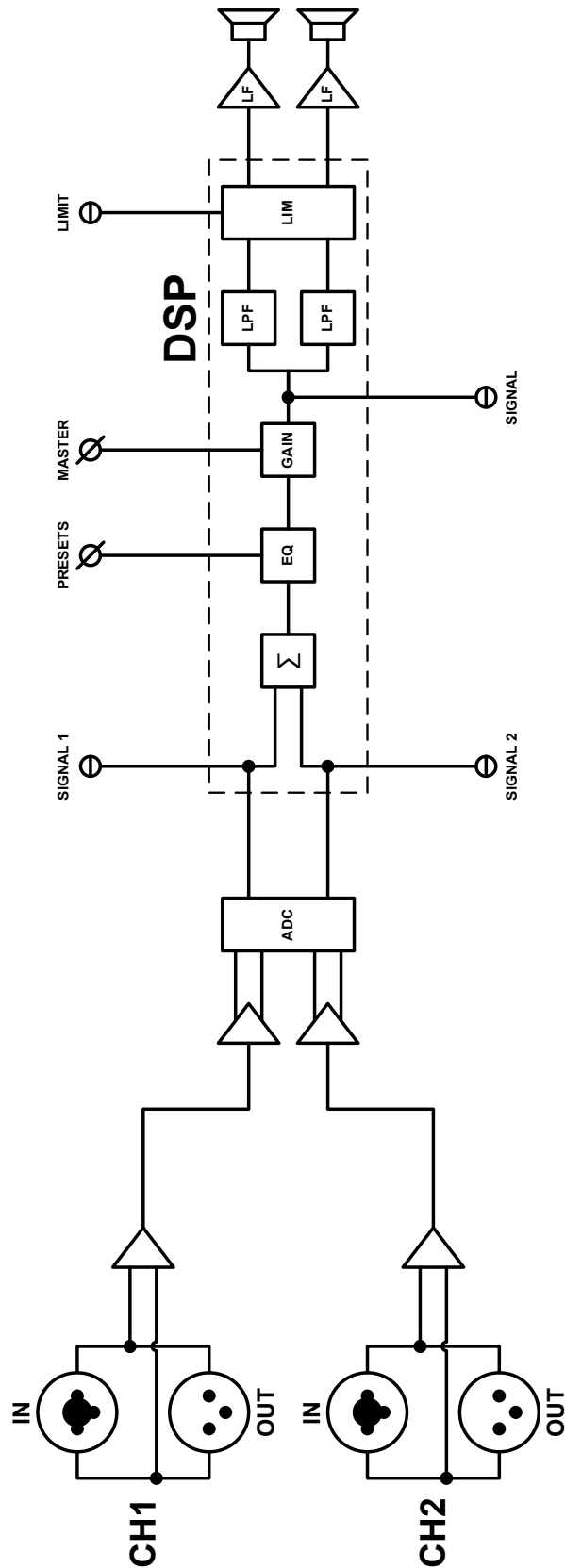

SRX812P SPECIFICATIONS

System Specification

System Type:	Self powered 12", two-way, bass-reflex
Maximum SPL Output:	136dB
Frequency Range (-10dB):	40Hz - 21kHz
Frequency Response (-3dB):	48Hz - 20kHz

Amplification

System Power Rating:	2000W Peak, 1500W Continuous
Input Impedance:	40k balanced, 20k unbalanced
Line Input Gain:	21 dB
Consumer Input Gain:	33 dB
Mic Input Gain:	45 dB
Maximum Input Level:	
• Line:	20dBu
• Consumer:	8dBu
• Mic:	-4dBu
Connectors:	Neutrik 1/4 - XLR input; Neutrik XLR Output
LED Indicators:	Power LED (Green), Network Link (Green), Network Data (Yellow)
Cooling:	On-Demand variable speed fan
AC Power Input:	100 - 240V~ 50/60Hz
AC Power Consumption (120V~):	2.2A (1/8th Power), 5.6A (1/3rd Power)

Speaker Specification

LF Driver:	2272F
HF Driver:	2432H
Coverage Pattern:	90 x 50
Crossover Frequency:	1.9kHz

Enclosure

Material:	18mm plywood
Monitor Angle:	Yes
Suspension/Mounting:	Dual 36mm pole socket, 12 x M10 Suspension points
Handles:	3
Finish:	Obsidian Duraflex™ finish
Grille:	Powder coated, Obsidian, 14-gauge perforated steel with acoustically transparent black cloth backing
Dimensions:	(L x W x H): 16.87" x 16.31" x 25.11" (429mm x 415mm x 638mm)
Weight:	58.0 lbs (26.4kg)
Shipping Weight:	67 lbs (30.5kg)

**For exact specifications including precise placement of suspension points and frequency response curves for JBL presets, find spec sheets at <http://www.jblpro.com/www/products/portable-market/srx800-series>*

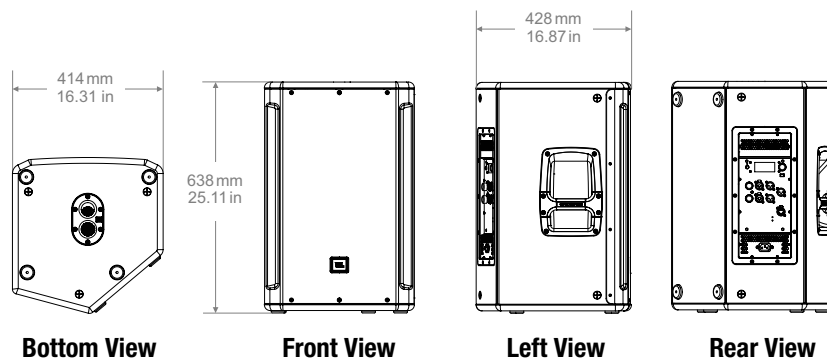

SRX815P SPECIFICATIONS

System Specification

System Type:	Self powered 15", two-way, bass-reflex
Maximum SPL Output:	137dB
Frequency Range (-10dB):	36Hz - 21kHz
Frequency Response (-3dB):	44Hz - 20kHz

Amplification

System Power Rating:	2000W Peak, 1500W Continuous
Input Impedance:	40k balanced, 20k unbalanced
Line Input Gain:	21 dB
Consumer Input Gain:	33 dB
Mic Input Gain:	45 dB
Maximum Input Level:	
• Line:	20dBu
• Consumer:	8dBu
• Mic:	-4dBu
Connectors:	Neutrik 1/4 - XLR input; Neutrik XLR Output
LED Indicators:	Power LED (Green), Network Link (Green), Network Data (Yellow)
Cooling:	On-Demand variable speed fan
AC Power Input:	100 - 240V~ 50/60Hz
AC Power Consumption (120V~):	2.2A (1/8th Power), 5.6A (1/3rd Power)

Speaker Specification

LF Driver:	2275F
HF Driver:	2432H
Coverage Pattern:	90 x 50
Crossover Frequency:	3kHz

Enclosure

Material:	18mm plywood
Monitor Angle:	Yes
Suspension/Mounting:	Dual 36mm pole socket, 12 x M10 Suspension points
Handles:	3
Finish:	Obsidian Duraflex™ finish
Grille:	Powder coated, Obsidian, 14-gauge perforated steel with acoustically transparent black cloth backing
Dimensions (L x W x H):	18.82" x 18.03" x 27.20" (478mm x 458mm x 691mm)
Weight:	63.0 lbs (28.6kg)
Shipping Weight:	73.0 lbs (33.2kg)

**For exact specifications including precise placement of suspension points and frequency response curves for JBL presets, find spec sheets at <http://www.jblpro.com/www/products/portable-market/srx800-series>*

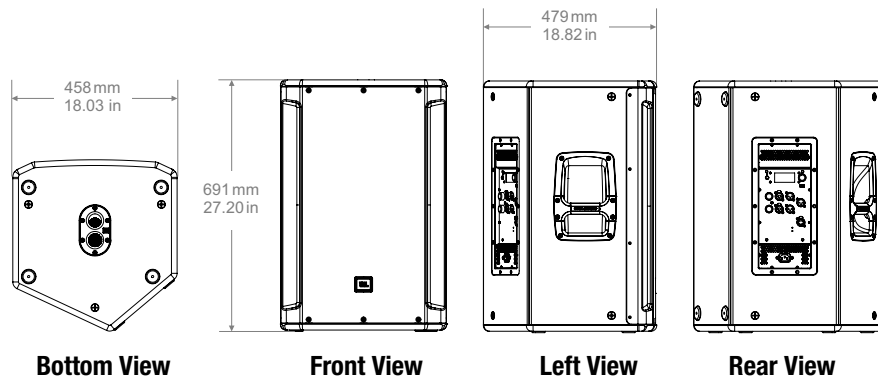

SRX835P SPECIFICATIONS

System Specification

System Type:	Self powered 15", three-way, bass-reflex
Maximum SPL Output:	137dB
Frequency Range (-10dB):	33Hz - 21kHz
Frequency Response (-3dB):	41Hz - 20kHz

Amplification

System Power Rating:	2000W Peak, 1500W Continuous
Input Impedance:	40k balanced, 20k unbalanced
Line Input Gain:	21 dB
Consumer Input Gain:	33 dB
Mic Input Gain:	45 dB
Maximum Input Level:	
• Line:	20dBu
• Consumer:	8dBu
• Mic:	-4dBu
Connectors:	Neutrik 1/4 - XLR input; Neutrik XLR Output
LED Indicators:	Power LED (Green), Network Link (Green), Network Data (Yellow)
Cooling:	On-Demand variable speed fan
AC Power Input:	100 - 240V~ 50/60Hz
AC Power Consumption (120V~):	2.2A (1/8th Power), 5.6A (1/3rd Power)

Speaker Specification

LF Driver:	2275F
MF Driver:	2107H
HF Driver:	2432H
Coverage Pattern:	60 x 40
Crossover Frequency:	330Hz & 2.4kHz

Enclosure

Material:	18mm plywood
Suspension/Mounting:	Single 36mm pole socket, 12 x M10 Suspension points
Handles:	2
Finish:	Obsidian Duraflex™ finish
Grille:	Powder coated, Obsidian, 14-gauge perforated steel with acoustically transparent black cloth backing
Dimensions (L x W x H):	18.74" x 21.4" x 38.74" (476mm x 544mm x 984mm)
Weight:	85.0 lbs (38.6kg)
Shipping Weight:	97.0 lbs (44.0kg)

**For exact specifications including precise placement of suspension points and frequency response curves for JBL presets, find spec sheets at <http://www.jblpro.com/www/products/portable-market/srx800-series>*

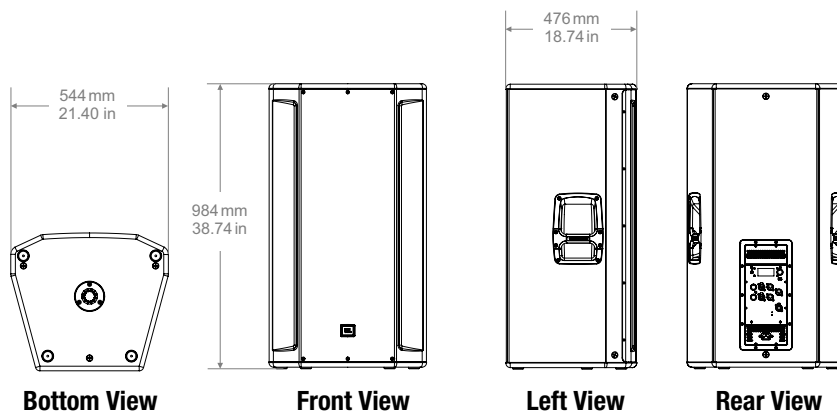

SRX818SP SPECIFICATIONS

System Specification

System Type:	Self powered 18", subwoofer system
Maximum SPL Output:	135dB
Frequency Range (-10dB):	29Hz - 150Hz
Frequency Response (-3dB):	35Hz - 120Hz

Amplification

System Power Rating:	1000W Peak , 750W Continuous
Input Impedance:	40k balanced, 20k unbalanced
Line Input Gain:	21 dB
Consumer Input Gain:	33 dB
Maximum Input Level:	
• Line:	20dBu
• Consumer:	8dBu
Connectors:	Neutrik 1/4 - XLR input; Neutrik XLR Output
LED Indicators:	Power LED (Green), Network Link (Green), Network Data (Yellow)
Cooling:	On-Demand variable speed fan
AC Power Input:	100 - 240V~ 50/60Hz
AC Power Consumption (120V~):	2.2A (1/8th Power), 5.6A (1/3rd Power)

Speaker Specification

LF Driver:	2279F
Crossover Frequency:	80Hz

Enclosure

Material:	18mm plywood
Suspension/Mounting:	M20 Threaded Pole Mount
Handles:	4
Finish:	Obsidian Duraflex™ finish
Grille:	Powder coated, Obsidian, 14-gauge perforated steel with acoustically transparent black cloth backing
Dimensions (L x W x H):	26.89" x 26.92" x 22.62" (683mm x 684mm x 575mm)
Weight:	87.0 lbs (39.5kg)
Shipping Weight:	103 lbs (46.8kg)

**For exact specifications including precise placement of suspension points and frequency response curves for JBL presets, find spec sheets at <http://www.jblpro.com/www/products/portable-market/srx800-series>*

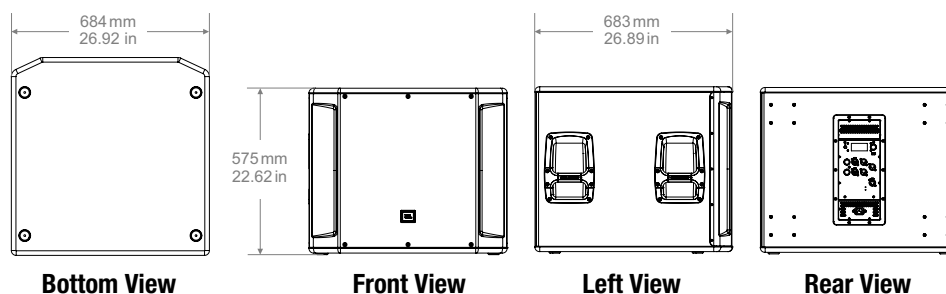

SRX828SP SPECIFICATIONS

System Specification

System Type:	Self powered dual 18", subwoofer system
Maximum SPL Output:	141dB
Frequency Range (-10dB):	29Hz - 150Hz
Frequency Response (-3dB):	35Hz - 120Hz

Amplification

System Power Rating:	2000W Peak (1000W x 2), 1500W continuous (750W x 2)
Input Impedance:	40k balanced, 20k unbalanced
Line Input Gain:	21 dB
Consumer Input Gain:	33 dB
Maximum Input Level:	
• Line:	20dBu
• Consumer:	8dBu
Connectors:	Neutrik 1/4 - XLR input; Neutrik XLR Output
LED Indicators:	Power LED (Green), Network Link (Green), Network Data (Yellow)
Cooling:	On-Demand variable speed fan
AC Power Input:	100 - 240V~ 50/60Hz
AC Power Consumption (120V~):	2.2A (1/8th Power), 5.6A (1/3rd Power)

Speaker Specification

LF Driver:	(2x) 2279F
Crossover Frequency:	80Hz

Enclosure

Material:	18mm plywood
Handles:	8
Finish:	Obsidian Duraflex™ finish
Grille:	Powder coated, Obsidian, 14-gauge perforated steel with acoustically transparent black cloth backing
Dimensions (L x W x H):	26.79" x 47.42" x 22.57" (681mm x 1205mm x 574mm)
Weight:	145.0 lbs (65.9kg)
Shipping Weight:	165.0 (75.0kg)

**For exact specifications including precise placement of suspension points and frequency response curves for JBL presets, find spec sheets at <http://www.jblpro.com/www/products/portable-market/srx800-series>*

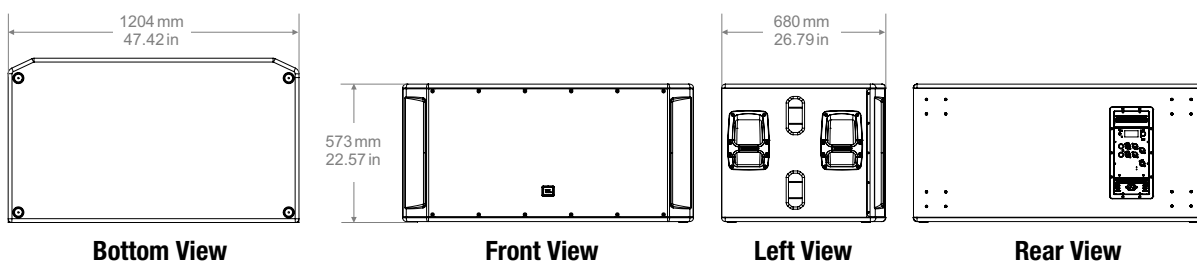

PURPOSEFUL PRODUCT DESIGN

Portability made easy

The SRX800 series was designed as a versatile all-in-one solution for a variety of applications including touring and permanent installations. Special attention was given to the needs of consumers who require a high level of ruggedness, reliability, and portability. To those ends, these systems feature 14 gauge steel grilles with “L” beam indents on either side for increased structural rigidity. The speakers are constructed from 18mm plywood to withstand drops, bumps and whatever else will be thrown at them. All models feature our patented DuraFlex coating which is made to survive years of abuse.

To make sure the speakers are easy to move around and comfortable to use, engineers developed an ergonomic handle cup that allows users to pick the speakers up without cutting off circulation to their hands. Also included are multiple M10 suspension points and rubber feet for the monitor angle so that whether the speakers are suspended, used as stage monitors, mounted to a pole or tripod, or stood on the floor or a shelf, they will stay securely in place and deliver sound wherever it's needed. The subwoofers have indexing feet for stacking in both standard and cardioid configurations. The back panel features glow in the dark ink and an LED screen so that users can connect and control the speaker in darker areas without having to turn on lights or reach for a control device.

Pole Mount

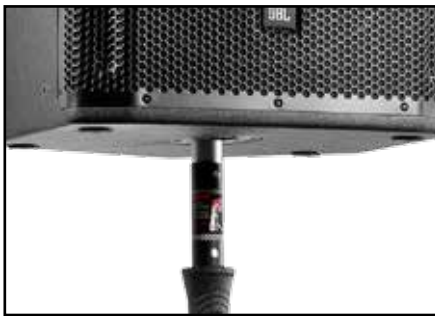

M10 Suspension Points



Multiple Handles & Indexed Feet



Side Handle



Secure Stacking

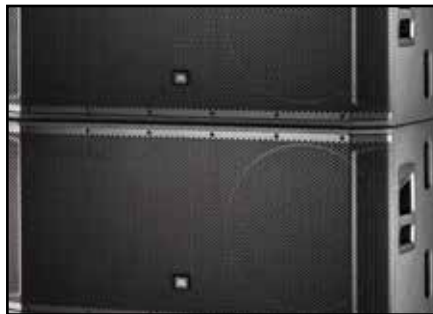

Monitor Position



COMPONENT ELEMENTS

High Performance Without Compromise

From the brand new transducers to the 14-gauge steel grilles, each component in the SRX800 Series was specifically designed for optimal performance in these systems. Featuring a purpose-built Crown amplifier and a full suite of user configurable DSP, these systems deliver the latest technologies from Harman Professional in one easy to use, high performing platform.



2432H HF Driver

High frequencies are handled by the JBL 2432H 3" voice-coil Compression Driver - the only 3" voice coil in this class. In addition to the weight reduction provided by neodymium, the large voice coils and diaphragms in these drivers are capable of handling very high power levels with reduced distortion and increased phase coherence resulting in smooth, crystal clear high frequencies.



Low Frequency Drivers

JBL's patented Differential Drive® Technology ferrite drivers incorporate 3" voice coils with lower mass ferrite magnets for reduced weight while maximizing power amp efficiency with greater heat dissipation and increased power handling resulting in exceptionally low distortion and extended low frequency response.

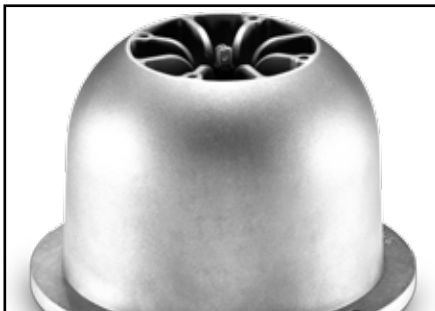

Mid Frequency Drivers

SRX835's midrange driver is derived from the midrange transducer on the VTX 20 touring line array system. The outside cast aluminum frame acts as the structural support, acoustic cavity, and heat sink for the driver, optimizing both space in the speaker cabinet and the performance of the system at the same time.



Patented (PT) Waveguides

High frequency drivers use JBL's patented Progressive Transition Waveguides which offer dramatically improved constant beamwidth and directivity, lower distortion, and overall smooth frequency response free of high-Q peaks. Wide coverage angles are achieved without compromise and harmonic distortion is minimized to allow maximum SPL capability of the compression drivers without harshness.

COMPONENT ELEMENTS



HiQnet Network Control

With full HiQnet Network Integration, configuring an SRX800 system is dramatically simplified, saving time while fully automating the control interface configuration. Simple wired control is provided via Ethercon connector and third party wireless router capability is included. Control options include Audio Architect, HiQnet Motion Control™ iOS app, and SRX Connect, a standalone app for iOS and Android.



Premium DSP Technology

A full suite of User configurable DSP driven by the SRX800 series' powerful onboard 400mHz Sharc DSP includes 20 PEQs, up to 2 seconds of delay, signal generators, input mixing, amplifier monitoring, and 50 User Presets. In addition, the system features 96kHz FIR filters, LevelMax™ Limiting, and is compatible with V5 JBL Tunings, providing compatibility with our flagship Vertec and VTX touring systems.



Crown DriveCore Technology Amplification

Each model is powered by Crown Proprietary Front-End DriveCore technology featuring a massive 2000W Power Rating, the highest power rating in this class of loudspeakers. With an outstandingly high 103dB signal-to-noise ratio, the SRX800 Series is capable of massive sound pressure levels with exceptional headroom, very low distortion and absolute clarity throughout its frequency range. A true universal power supply w/ PFC and locking IEC power cords ensure quick and secure connection for easy setups.

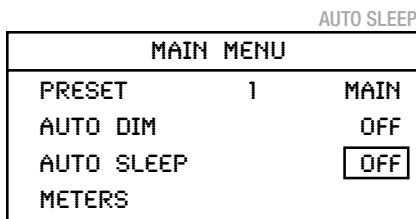
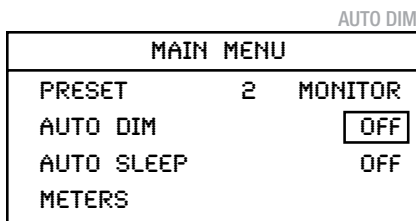
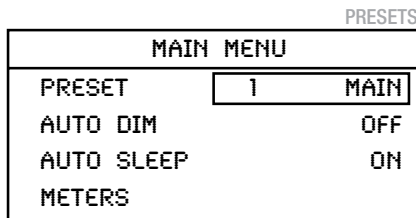
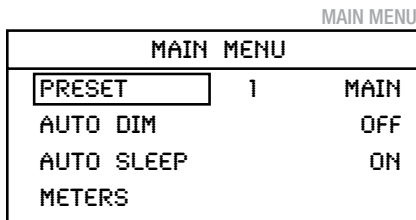
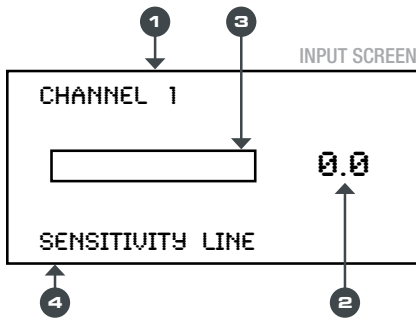
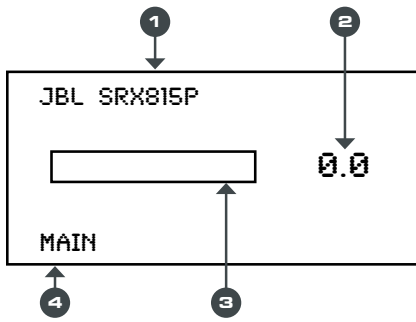

Introduction

The LCD Screen on the back panel of the speaker allows basic control of the system, as well as access to presets and network settings.

Plug in the system and power it on. Once the amp boots up, this screen will be displayed. This screen will also be displayed after one minute of inactivity. It can also be accessed by pressing the Back Button 5 times to exit all menus.

1. Speaker Model Name
2. Master Attenuator Level. Turn the Master Encoder to adjust between -100 and +12
3. Main Output Meter
4. Preset Indicator

Input Screen

From the Home Screen, press either one of the Channel Encoders to access the Input Screen for the channel. Press the Back Button or wait one minute to return to the Home Screen.

1. Channel Indicator. Press the other Channel Encoder to switch channels.
2. Input Attenuator Level. Turn the Channel encoder to adjust from -80 to +12.
3. Channel Input Meter
4. Sensitivity Setting Indicator. Press the Channel Encoder to highlight the setting, then turn to adjust between Line (default,) Consumer, and Mic. Once the desired level is selected, press the Channel Encoder down again to set it.

Main Menu

From the Home Screen, press the Master Encoder to access the Main Menu. Loudspeaker Settings and Presets are accessed from the Main Menu

Presets

From the Main Menu, turn the Master Encoder until "Preset" is highlighted. Press the Master Encoder to access Presets. Turn the Master Encoder to scroll through Presets and then press the Master Encoder to select the desired Preset. Once the Preset is selected, you will be returned to the Main Menu. Hitting the Back Button at any time will also return you to the Main Menu.

Auto Dim

Toggleing the Auto Dim on and off will determine whether or not the LCD panel on the speaker dims after a minute of not being used.

From the Main Menu, turn the Master Encoder until "Auto Dim" is highlighted. Press the Master Encoder to access Auto Dim. Turn the Master Encoder to toggle between "On" and "Off." Once the desired setting is displayed, press the master encoder to select that setting; you will be returned to the Main Menu. Hitting the Back Button at any time will also return you to the Main Menu.

Auto Sleep

Toggleing the Auto Sleep on or off will determine whether or not the speaker goes into Sleep Mode after a period of time. In Sleep Mode, the outputs will be completely turned off so that any spurious outside noise such as radio signals will not be passed through the system. The speaker will come out of sleep mode as soon as audio is passed through the system again.

From the Main Menu, turn the Master Encoder until "Auto Sleep" is highlighted. Press the Master Encoder to access Auto Sleep. Turn the Master Encoder to toggle between "On" and "Off." Once the desired setting is displayed, press the master encoder to select that setting; you will be returned to the Main Menu. Hitting the Back Button at any time will also return you to the Main Menu.

BACK PANEL LCD

INPUT METERS

INPUT METERS	
CH1	<input type="text"/>
CH2	<input type="text"/>

NETWORK MENU 1 - IP

NETWORK MENU	
IP	169.254.155.248
SUBNET	255.255.0.0
HIQNET	1
DHCP	ON

NETWORK MENU 2 - SUBNET

NETWORK MENU	
IP	169.254.155.248
SUBNET	255.255.0.0
HIQNET	1
DHCP	ON

NETWORK MENU 3 - HIQNET

NETWORK MENU	
IP	169.254.155.248
SUBNET	255.255.0.0
HIQNET	1
DHCP	ON

NETWORK MENU 4 - DHCP

NETWORK MENU	
IP	169.254.155.248
SUBNET	255.255.0.0
HIQNET	1
DHCP	ON

INFORMATION

INFORMATION	
MODEL	JBL SRX815P
VERSION	0.0.3.4
MAC	00:0A:40:10:05:C5

Meters

From the Main Menu, turn the Master Encoder until "Meters" is highlighted. Press the Master Encoder to access Meters. Input Meters for both channels will be displayed. Press the Back Button to return to the Main Menu or wait one minute to be returned to the Home Screen.

Network Menu

From the Main Menu, turn the Master Encoder until "Network Menu" is highlighted. Press the Master Encoder to access the Network Menu.

Adjustments to the systems IP address, Subnet Address, and HiQNet Address can be made from the Network Menu. Please note that "DHCP" must be set to "Off," in order to manually adjust the IP or Subnet addresses.

1. IP.

In the Network Menu, turn the Master Encoder until "IP" is highlighted. Press the Master Encoder to access the IP address. Turn the Master Encoder to adjust each digit string of the IP address. Once a digit string is set to its desired value, press the Master Encoder to move to the next string. Once the entire IP address is set, press the Master Encoder to save changes. Pressing the Back Button at any time will cancel changes and return you to the Network Menu.

2. SUBNET.

In the Network Menu, turn the Master Encoder until "SUBNET" is highlighted. Press the Master Encoder to access the SUBNET address. Turn the Master Encoder to adjust each digit string of the SUBNET address. Once a digit string is set to its desired value, press the Master Encoder to move to the next string. Once the entire SUBNET address is set, press the Master Encoder to save changes. Pressing the Back Button at any time will cancel changes and return you to the Network Menu.

3. HiQNet

In the Network Menu, turn the Master Encoder until "HiQNet" is highlighted. Press the master encoder to access the HiQNet address. Turn the Master Encoder to scroll to the desired HiQNet address. Once the desired HiQNet address is displayed, press the Master Encoder to select that address and return to the Network Menu.

4. DHCP

In the Network Menu, turn the Master Encoder until "DHCP" is highlighted. Press the Master Encoder to access DHCP. Turn the Master Encoder to toggle between "On" and "Off." Once the desired setting is displayed, press the master encoder to select that setting; you will be returned to the Network Menu. Hitting the Back Button at any time will also return you to the Network Menu. NOTE: "DHCP" must be set to "Off," in order to manually adjust the IP or Subnet addresses.

Information

From the Main Menu, turn the Master Encoder until "Information" is highlighted. Press the Master Encoder to access Information. The Model Number of the system, software version, and MAC address are displayed in this screen. Press the Back Button to return to the Main Menu.

Main

This is the standard tuning for SRX812P, SRX815P, and SRX835P for use without a subwoofer.

Monitor

Monitor tuning can be used for both SRX812P and SRX815P when they are deployed in the monitor position.

Speech

This is an ideal preset for speech intelligibility on the SRX812P, SRX815P, and SRX835P

SRX Sub

This is the preset to use in the SRX812P, SRX815P, and SRX835P when they are used with either the SRX818SP or the SRX828SP. This preset matches the performance of the SRX full range systems to the SRX subwoofers precisely, making for an ideal subwoofer/satellite system.

SRX Top

This is the preset to use in the SRX818SP and SRX828SP when they are used with the SRX812P, SRX815P, or SRX835P. This preset matches the performance of the SRX full range systems to the SRX subwoofers precisely, making for an ideal subwoofer/satellite system.

60Hz Sub, 80Hz Sub, 100Hz Sub, 120Hz Sub

These are the tunings to use with the SRX812P, SRX815P, and SRX835P when they are used with a subwoofer other than SRX818SP or SRX828SP. Depending on the range and specifications of the subwoofer, different crossover points are provided to make an ideal match.

60Hz , 80Hz , 100Hz , 120Hz

These are the tunings to use with the SRX818SP and SRX828SP when they are used with full range systems other than the SRX812P, SRX815P, and SRX835P. Depending on the range and specifications of the full range speakers, different crossover points are provided to make an ideal match.

Cardioid 60, Cardioid 80

These tunings are to be used in the rear-facing subwoofers only in cardioid systems. Select the desired frequency for the crossover based on what the tunings used in the front-facing subwoofers. Use Cardioid 80 if the other subwoofers are set to SRX Top.

SRX PRESETS

Preset Crossovers

Presets are included to use SRX with a variety of different full range speakers and subwoofers. This chart details which presets to use in which systems to achieve optimal performance.

		SRX 812/815	SRX 835	Generic Top Box 60Hz Sub Crossover	Generic Top Box 80Hz Sub Crossover	Generic Top Box 100Hz Sub Crossover	Generic Top Box 120Hz Sub Crossover
SRX 818	Normal	SRX Sub SRX Top	SRX Sub SRX Top	60Hz HiPass 60Hz	80Hz HiPass 80Hz	100Hz HiPass 100Hz	120Hz HiPass 120Hz
	Cardioid 80Hz	SRX Sub Cardioid 80Hz*	SRX Sub Cardioid 80Hz*		80Hz HiPass Cardioid 80Hz*		
	Cardioid 60Hz		60Hz Sub Cardioid 60Hz*	60Hz HiPass Cardioid 60Hz*			
SRX 828	Normal	SRX Sub SRX Top	SRX Sub SRX Top	60Hz HiPass 60Hz	80Hz HiPass 80Hz	100Hz HiPass 100Hz	120Hz HiPass 120Hz
	Cardioid 80Hz	SRX Sub Cardioid 80Hz*	SRX Sub Cardioid 80Hz*		80Hz HiPass Cardioid 80Hz*		
	Cardioid 60Hz		60Hz Sub Cardioid 60Hz*	60Hz HiPass Cardioid 60Hz*			
Generic Subs	60Hz		60Hz Sub 60Hz LoPass				
	80Hz		80Hz Sub 80Hz LoPass				
	100Hz		100Hz Sub 100Hz LoPass				
	120Hz		120Hz Sub 120Hz LoPass				

*The Cardioid Preset is always selected only on the rear-facing box. The two front facing boxes should be set to your selected crossover frequency, eg. 60Hz or 80Hz.

PREMIUM DSP TECHNOLOGY



DSP



Controller



Networking

Introduction

The onboard suite of user controllable DSP featured in SRX800 allows users to set up and fine tune their systems with an extremely high degree of ease and precision. In addition to the JBL engineered application presets, users can define and recall their own presets for use in a variety of settings and applications.

V5 Compatible JBL Tunings

- 96kHz FIR Filters
- LevelMax™ Limiting

Full Suite of User Controllable DSP

- 20 PEQs with a full suite of filters
- 2 sec of delay
- Signal Generator: Pink Noise, White Noise, and Sine Waves
- Input mixing
- Amplifier Monitoring: Input Voltage, Thermal Errors, Clip
- 50 User Presets

SRX Connect App

Basic control over the system is provided through the SRX Control App, available for iOS, and android devices. Typical setups are easily achieved and controlled via this app.

Audio Architect

For more advanced configurations, users can control the system using Audio Architect. Audio Architect provides incredible flexibility with the same components scaling from an 80,000 seat stadium down to a small performing arts center. Here it seamlessly continues to act as the vehicle for artistic expression by delivering the highest quality sound reproduction and enabling the artists to convey a dazzling performance. Whether a theater of 200 or 2,000, the HARMAN solution raises the roof.

NETWORKING

SRX800 Speakers feature an Ethernet connector so that they can be controlled via Audio Architect (version 1.60 or later) or SRX Connect. The latest versions of both of these programs can be found at <http://www.jblpro.com/www/products/portable-market/srx800-series>.

When a connection is established, the LINK LED on the back panel of the speaker will illuminate. The DATA LED will also light to indicate that the speaker is sending and receiving information via the network.



There are several options for connecting the speakers to a network:

1. Direct Connection

Simply plug an Ethernet cable into both the SRX speaker and your computer. You can now control this individual speaker.

2. Wired connection

Connect any number of SRX speakers to a wired network router, either directly or via a switcher, and connect your computer to that same network. You can now control all speakers on the network.

3. Wireless connection

Connect any number of SRX speakers to a wireless router either directly or via a switcher, and connect your computer or tablet to that same network. You can now control all speakers on the network. Wireless connection is the only option for tablet control via the SRX Connect app for iPad and Android tablets.

HiQnet audioarchitect™

SRX800 Speakers can be used in Audio Architect version 1.60 and later. Audio Architect can be used to control all DSP parameters of SRX800. Some functions, such as building and saving DSP presets in the speakers themselves, are only available through Audio Architect. To download Audio Architect, visit <http://www.jblpro.com/www/products/portable-market/srx800-series> and select the latest version of Audio Architect.

See the networking section above for instructions on connecting speakers to a network.

Some users will not see every speaker on the network the first time they connect new speakers. The most probable cause for this is that two or more speakers are automatically set to the same HiQnet address when they are brand new. Each speaker must have its own unique HiQnet address in order for the system to recognize them. If you aren't seeing connected speakers on your network, you can use HiQnet NetSetter to reset the HiQnet addresses of speakers on the system. NetSetter can be downloaded at <http://www.jblpro.com/www/products/portable-market/srx800-series>.

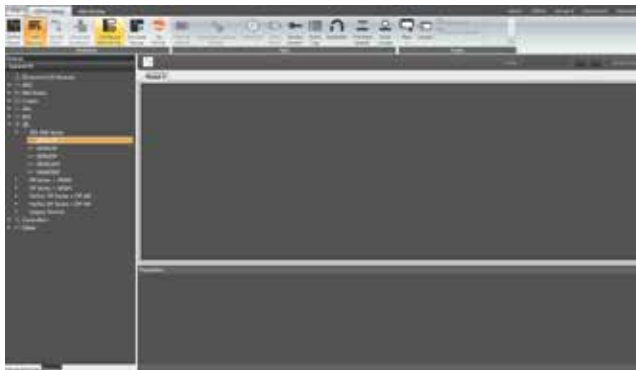

Once your speakers are networked, they will show up in the left hand panel on audio architect. A full list of Audio Architect compatible Harman devices is also available for creating shows while offline.

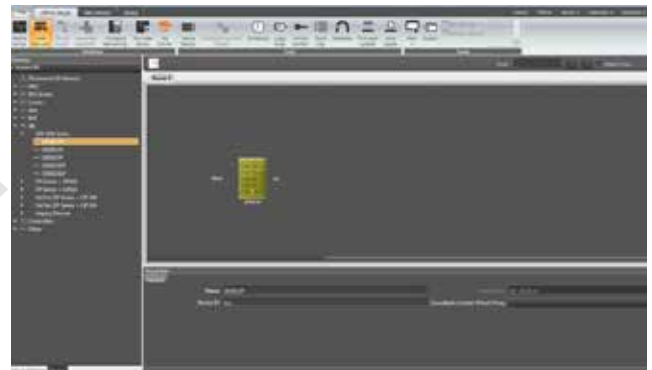

Drag speakers from the left hand panel into the room to start working with them.



Double-click the speaker to bring up its control panel.



Double-click any of the DSP parameters to adjust those.

More in-depth instructions on using SRX with Audio Architect can be found at <http://www.jblpro.com/www/products/portable-market/srx800-series>

SMART DEVICE APP

Introduction

For ease of use, SRX800 can be controlled via a proprietary app, SRX Connect, which is available for Android and iOS devices. It may be found at <http://www.jblpro.com/www/products/portable-market/srx800-series>. Once the speakers are online and connected to the network, connect your device to that same network and the app will find the speakers.



Drag and Drop speakers from the network into their configuration to get started.



Levels can be set directly from the configuration screen.

Selecting a group of speakers will allow users to adjust control DSP and tune the system.

A full user's guide for the app can be found online at <http://www.jblpro.com/www/products/portable-market/srx800-series/app>

LOUDSPEAKER PLACEMENT AND SUSPENSION

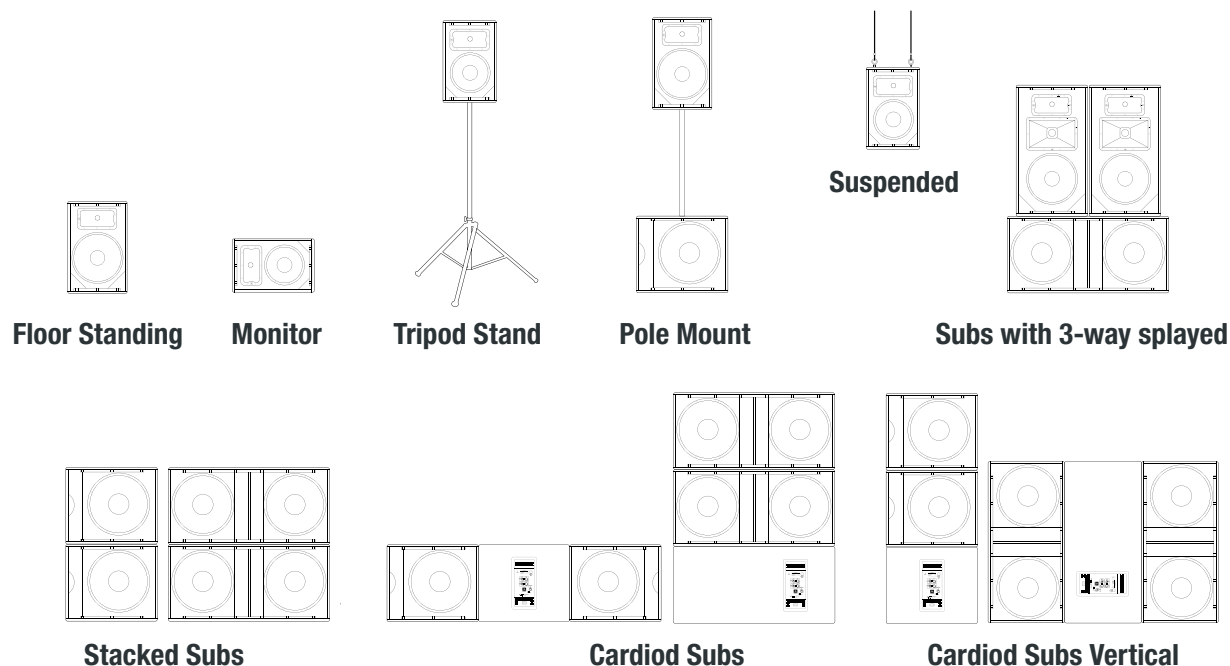

The following guidelines will help you achieve optimum sound wherever you use your SRX800 loudspeakers. Only experienced professionals should attempt to suspend the speakers. For permanent installation applications utilizing the M10 suspension points, JBL Professional recommends the use of M10 x 1.5 thread pitch forged shoulder steel eyebolts with an 18-20mm threaded shaft, along with fender washers, rated for overhead suspension. USERS UNFAMILIAR WITH SAFE RIGGING PRACTICES SHOULD NOT ATTEMPT TO SUSPEND LOUDSPEAKERS. Please see https://www.jblpro.com/pub/technote/tn_v1n14.pdf for more information.

Aim the speakers to cover the whole audience

For best results try to get the high frequency horn at least 2 to 4 feet above the heads of the audience. If the speakers are too low, the people in the back of the audience will not receive the best quality sound. If the speakers are too high, people in the front of the audience will not receive the best quality sound. Pay attention to the coverage pattern of each speaker and aim them so that the entire audience is within the coverage pattern of the system. Utilize the downward angle pole cup on the SRX812P and SRX815P for closer audiences in smaller spaces.

Place the speakers between the microphones and the audience.

Feedback occurs when the microphones pick up sound from the speakers and “feed” the sound back through the sound system. If space is limited, point the speakers away from the microphones to reduce feedback.

Locate the speakers away from turntables.

Low-frequency feedback occurs when the output of the speaker is picked up by the tone arm of the turntable and is re-amplified. A heavy, solid turntable base and shock mounting can also reduce this type of feedback in DJ applications.

Use more speakers in large or highly reverberant spaces.

Spreading speakers throughout these spaces will produce much better sound than trying to compensate with loudness level or equalization. For very long distances, the use of another set of speakers with time delay is recommended.

Stand speakers upright for PA - Lay speakers on their side for stage monitoring.

Use the full range speakers in upright stance for even coverage over a wide area. SRX815P and SRX812P speakers are also designed with a slanted position for stage monitoring applications. Rest the speaker on the side with rubber feet for use as a stage monitor. Two SRX835Ps can be splayed side by side for wide coverage for large audiences. Simply stand them so that their inside side panels meet. This configuration is ideal atop an SRX828SP subwoofer.

TROUBLESHOOTING

Symptom	Likely Cause	What to do
No sound	Speaker not connected to active AC power	Verify that speaker is connected and that the circuit is on
	Power not switched on	Switch on power and verify that power LED is on
No sound, speaker is connected to working AC power but won't come on.	Speaker power cable is faulty or improperly connected.	<ul style="list-style-type: none"> • Re-seat the power cable at both ends. • Substitute a known-good power cable
No sound. Speaker comes on.	Signal source (mixer, instrument, etc.) is not sending.	<ul style="list-style-type: none"> • Check VU meters on the source mixer • Verify that the tape or CD is playing. • Use headphones to verify that the instrument is actually sending an audio signal
	Faulty cables and connections	<ul style="list-style-type: none"> • Disconnect and re-seat signal cables. • Replace suspected cable with a known-good cable
No sound with microphone connected directly to the input.	Microphone requires phantom power	The SRX800 does not supply phantom power. Switch to a dynamic microphone, use a battery powered microphone (if possible), use an external phantom power supply for condenser type microphones.
Signal sounds distorted and very loud, PEAK light is lit most of the time.	Excessive input signal, trying to exceed the capabilities of the speakers	<ul style="list-style-type: none"> • Reduce the output level of the source. • Turn down the level controls on the speaker. • Use additional SRX800 speakers.
Signal sounds distorted even at moderate volumes, LIMIT light is not lit.	Mixer or other source is overdriven	<p>Review the Owner's Manual for your mixer and adjust controls as needed.</p> <ul style="list-style-type: none"> • Input sensitivity (gain) • Channel faders • Master faders Once this is done, review the instructions in the Quick Start section of this guide.
Lots of hiss in the sound, the mixer controls are at very low settings.	Improper gain structure	<ul style="list-style-type: none"> • Make sure that the MIC/LINE switch is in the LINE (disengaged) position. • Reduce the level settings at speaker. Review the Owner's Manual for your mixer and adjust controls as needed. • Input sensitivity (gain) • Channel faders • Master faders
Noise or hiss heard at output.	Noisy source device	Disconnect the devices that are connected to your speaker one at a time. If the noise goes away, the problem is with the source or the connecting cable.
Hum or Buzz that increases or decreases when the mixer level controls are moved.	Improper A/C ground or faulty equipment connected to mixer input	Disconnect or mute channels one at a time to isolate the problem. Refer to the owner's manual of the faulty equipment for troubleshooting help.
	Faulty cable between source equipment and mixer	Substitute a known-good cable for the suspected faulty cable.
Hum or Buzz	Improper A/C grounding, ground loops	<ul style="list-style-type: none"> • 'Lift' the audio ground by using an XLR/F to XLR/M adapter on one end. • Re-route audio cables away from AC power and lighting cables.
	Excessively long unbalanced cable run	<ul style="list-style-type: none"> • Use the balanced outputs (if available) of your mixer or source equipment to drive your SRX800 speakers. • Use a "DI" (direct injection) box to convert your unbalanced equipment output to a balanced output.
	Improper system gain structure	Reduce the INPUT level controls and increase the output level of your source devices.

WARRANTY INFORMATION

The JBL Limited Warranty on professional loudspeaker products (except for enclosures) remains in effect for five years from the date of the first consumer purchase. JBL amplifiers are warranted for three years from the date of original purchase. Enclosures and all other JBL products are warranted for two years from the date of original purchase.

Who Is Protected By This Warranty?

Your JBL Warranty protects the original owner and all subsequent owners so long as: A.) Your JBL product has been purchased in the Continental United States, Hawaii or Alaska. (This Warranty does not apply to JBL products purchased elsewhere except for purchases by military outlets. Other purchasers should contact the local JBL distributor for warranty information.); and B.) The original dated bill of sale is presented whenever warranty service is required.

What Does The JBL Warranty Cover?

Except as specified below, your JBL Warranty covers all defects in material and workmanship. The following are not covered: Damage caused by accident, misuse, abuse, product modification or neglect; damage occurring during shipment; damage resulting from failure to follow instructions contained in your Instruction Manual; damage resulting from the performance of repairs by some SRX800 not authorized by JBL; claims based upon any misrepresentations by the seller; any JBL product on which the serial number has been defaced, modified or removed.

Who Pays For What?

JBL will pay all labor and material expenses for all repairs covered by this warranty. Please be sure to save the original shipping cartons because a charge will be made if replacement cartons are requested. Payment of shipping charges is discussed in the next section of this warranty.

How To Obtain Warranty Performance

If your JBL product ever needs service, write or telephone us at JBL Incorporated (Attn: Customer Service Department), 8500 Balboa Boulevard, PO. Box 2200, Northridge, California 91329 (818/893-8411). We may direct you to an authorized JBL Service Agency or ask you to send your unit to the factory for repair. Either way, you'll need to present the original bill of sale to establish the date of purchase. Please do not ship your JBL product to the factory without prior authorization. If transportation of your JBL product presents any unusual difficulties, please advise us and we may make special arrangements with you. Otherwise, you are responsible for transporting your product for repair or arranging for its transportation and for payment of any initial shipping charges. However, we will pay the return shipping charges if repairs are covered by the warranty.

Limitation of Implied Warranties

ALL IMPLIED WARRANTIES, INCLUDING WARRANTIES OF MERCHANTABILITY AND FITNESS FOR PARTICULAR PURPOSE, ARE LIMITED IN DURATION TO THE LENGTH OF THIS WARRANTY.

EXCLUSION OF CERTAIN DAMAGES

JBL'S LIABILITY IS LIMITED TO THE REPAIR OR REPLACEMENT, AT OUR OPTION, OF ANY DEFECTIVE PRODUCT AND SHALL NOT INCLUDE INCIDENTAL OR CONSEQUENTIAL DAMAGES OF ANY KIND. SOME STATES DO NOT ALLOW LIMITATIONS ON HOW LONG AN IMPLIED WARRANTY LASTS AND/OR DO NOT ALLOW THE EXCLUSION OF INCIDENTAL OR CONSEQUENTIAL DAMAGES, SO THE ABOVE LIMITATIONS AND EXCLUSIONS MAY NOT APPLY TO YOU. THIS WARRANTY GIVES YOU SPECIFIC LEGAL RIGHTS, AND YOU MAY ALSO HAVE OTHER RIGHTS, WHICH VARY, FROM STATE TO STATE.

JBL Professional

8500 Balboa Blvd. Northridge, CA 91329 USA

CONTACT INFORMATION



Mailing Address:

JBL Professional
8500 Balboa Blvd.
Northridge, CA 91329

Shipping Address:

JBL Professional
8500 Balboa Blvd., Dock 15
Northridge, CA 91329

(Do not return product to this address without first obtaining prior authorization from JBL)

Customer Service:

Monday through Friday
8:00am -5:00pm
Pacific Coast Time in the U.S.A.

(800) 8JBLPRO (800.852.5776)

www.jblproservice.com

On The World Wide Web:

www.jblpro.com

Professional Contacts, Outside the USA:

Contact the JBL Professional Distributor in your area.

A complete list of JBL Professional international distributors is provided at our U.S.A. website: www.jblpro.com

SRX800

S E R I E S