

◆ **MA series active DSP-controlled speaker**

MA Series is a portable active DSP-controlled speaker. It is Audiocenter's first lightweight integrated speaker crafted with excellent sound, compact size, and stylish industrial design. It is versatile, portable and plug-and-play, and can be used in various touring performances and fixed installations.

MA series cabinets are molded and made from a new type of polypropylene composite material. They are one-piece molded, strong and wear-resistant, and can suppress vibration even under high dynamics. The cabinet structure has been carefully tested and developed to achieve the ultimate acoustic performance, providing clear, delicate and smooth sound.

The MA series is built with the advanced BrainCore™ technology, which can deeply analyze and process signal input, Class D amplifier and DSP module, and optimizes the audio performance of the whole system. Built-in wireless Bluetooth makes MA can easily connect with various Bluetooth devices.

MA series has two models of full-range speakers, MA12 and MA15, and an subwoofer speaker, MA118. Both are created with features of excellent sound performance, compact size, and modern design, and easy to use. They can be used as PA speakers and stage monitor. There are multiple way of mounting and installation, for example, pole mount with a three-foot stand, or hanging installation.



◆ **Installation**

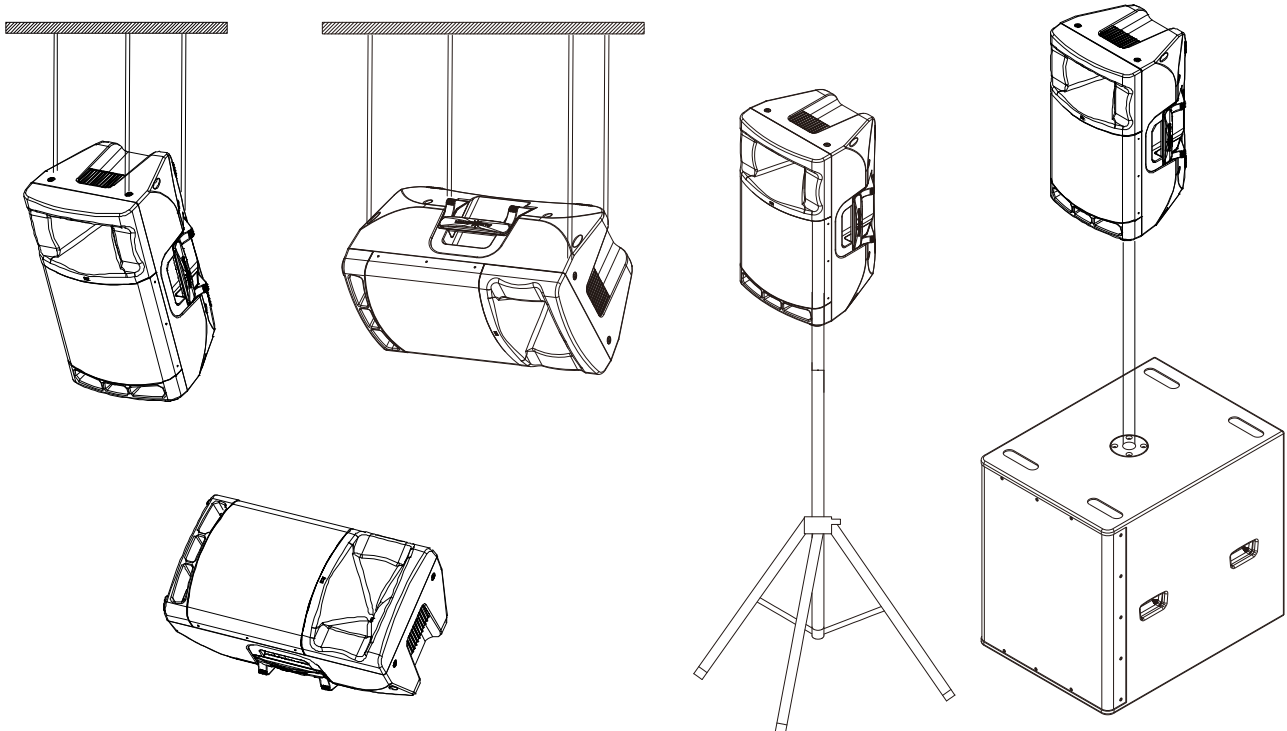

◆ Control panel and functions

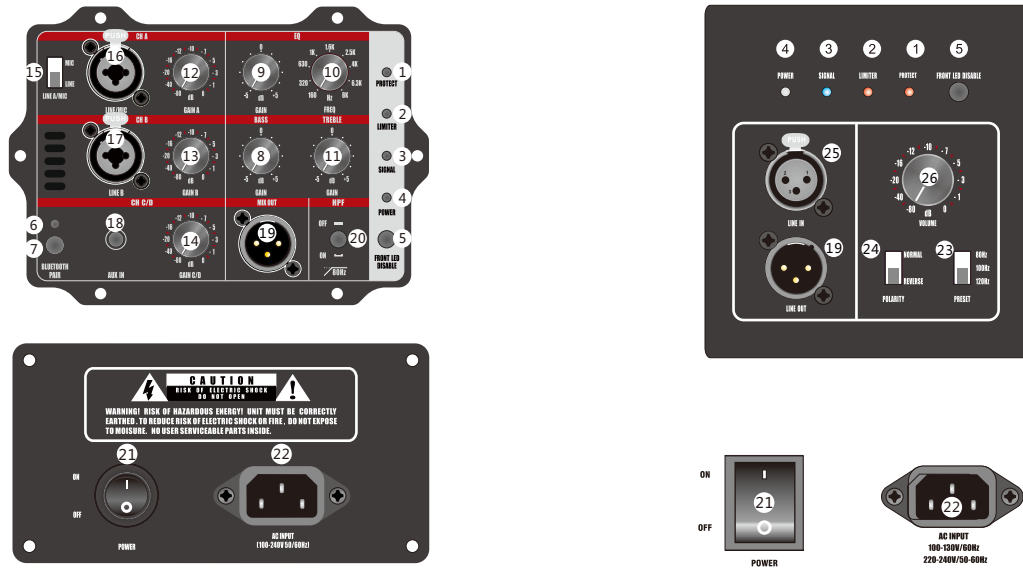

1 PROTECT indicator

The indicator is on when the system detects abnormal of the speaker and starts protection mode.

2 LIMITER indicator

The indicator is on when output limiter is activated. If the output voltage of the amplifier exceeds the maximum value, output limiter will be activated, lower the output signal of the amplifier.

3 SIGNAL indicator

The indicator is on when the input signal is detected.

4 POWER indicator

The indicator is on when speaker is connected to power.

5 FRONT LED DISABLE switch

Switch on and the front panel LED indicator is on (operating mode: blue);
Switch off when the front panel LED indicator is unneeded.

6 BLUETOOTH indicator

When the indicator is off, it indicates no connection to any Bluetooth devices (for example, mobile phone);

When the light is on, it indicates that the speaker has been successfully connected to Bluetooth devices (for example, mobile phone);

When the light is flashing (1 time in 1 sec), it indicates that the speaker is ready for Bluetooth pairing with a device (for example, mobile phone).

When the light is flashing (3 times in 1 sec), it indicates that the speaker is in Bluetooth speaker-to-speaker pairing mode (for the first time two speakers work as a pair they need to match each other).

Remark: The speaker-to-speaker pairing means two MA speakers can work as a pair (by Bluetooth) and connect to the same Bluetooth source (for example, mobile phone).

7 BLUETOOTH PAIR pairing button

If you want to connect speaker to a Bluetooth source (for example, a mobile phone), first press "Bluetooth pair" button for 3 seconds (the indicator flashes 1 time in 1 second), and then choose "AC-MA" as the Bluetooth source to pair.

If you want to pair two speakers for the first time, press "Bluetooth PAIR" button of both speakers for 5 seconds (Bluetooth indicator flashes 3 times in 1 second). The two speakers will be paired automatically.

8 BASS

This is a low shelf filter with 100Hz cut-off frequency. Turn the knob to reduce or boost the low frequency when signal frequency is lower than 100Hz.

9 EQ parameter equalizer

This is a Peaking Filter, used together with GAIN knob and FREQ knob.

10 FREQ: center frequency 160Hz, 320Hz, 630Hz, 1KHz, 1.6KHz, 2.5KHz, 4KHz, 6.3KHz, 8KHz optional. GAIN: reduce or boost the selected central frequency signal.

11 TREBLE

This is a High Shelf Filter with 10kHz cut-off frequency. Turn the knob to reduce or boost the high frequency when signal frequency is higher than 10KHz.

12 GAIN A control

Use GAIN A knob to control gain of input signal from LINE A/MIC. GAIN A can adjust the sensitivity and thus control the volume of signal sent to the amplifier and then to the speaker.

13 GAIN B control

Use GAIN B knob to control gain of input signal from LINE B. GAIN B can adjust the sensitivity and thus control the volume of signal sent to the amplifier and then to the speaker.

14 GAIN C/D control

Use GAIN C/D knob to control gain of input signal from BLUETOOTH C/D and AUX. GAIN C/D can adjust the sensitivity and thus control the volume of signal sent to the amplifier and then to the speaker.

15 LINE/MIC switch

According to the level of the input signal, set the LINE/MIC switch to LINE or MIC. For low-level signals (such as microphones), switch to the MIC position (upwards); for high-level signals (such as electroacoustic instruments and audio equipment), switch to the LINE position (downwards). Generally, when the microphone is not in use, the switch should be at LINE.

16 INPUTS socket(LINE A/ MIC)

Balanced XLR and PHONE type multi-purpose input socket.

17 INPUTS socket(LINE B)

Balanced XLR and PHONE type multi-purpose input socket.

18 INPUTS socket(AUX)

3.5mm input socket.

19 OUTPUTS socket(MIX OUT)

Balanced XLR output socket. Balance the mixed output signal (able to mix and integrate the signals of all channels).

20 HPF switch

Set cut-off frequency of the high pass filter at 80Hz, the filter will eliminate the frequency lower than 80Hz. Press the switch and activate the function of filter.

21 POWER switch

To turn on the power, pull the switch upwards to position (1); To turn off the power, pull the switch downwards to the position (0).

22 AC INPUT slot

Connect the power cable to the input slot first, and then connect to the AC power.

23 Preset three low pass filter

The low-pass filter cut off frequency specified in 120 Hz and 100 Hz and 80 Hz. The filter will cut frequency higher than the cut off frequency.

24 The polarity of SA3 series:

Polarity, also is called as phase, means that the input voltage is positive or negative in specific time. In most case, the positive will drive the diaphragm of the speaker to move forward, and the negative will pull it backward. When a specific frequency signal or similar signal repeats, the polarity must be the same, so that the input efficiency will be the highest, which is very important for subwoofer system. Wrong connection or usage will change the polarity, and lower the system's efficiency.

25 Input socket(LINE IN)

Balanced XLR input socket.(LINE IN)

26 VOLUME control knob

VOLUME knob controls the gain input signal of all the channels. This control can adjust the sensitivity, so as to control the amount of semaphore send to the power amplifier and then to the speakers.

 Note: MA series employs a universal power supply, supporting AC power input voltage range at 100-240Vac (50 / 60Hz), 100V-130V (50/60Hz)/220V-240V (50/60Hz). Please choose the right power cable.

MA Series Active Speaker

MA series parameters

	MA12	MA15	MA118
Frequency response (-6dB anechoic chamber)	50Hz-20KHz	50Hz-20KHz	32Hz-150Hz
Maximum SPL	131dB	133dB	134dB
LF driver	Customized driver, 2.5" voice coil	Customized driver, 3" voice coil	Customized driver, 4" voice coil
HF driver	Customized driver, 1.4" voice coil, 1.0" exit		/
Coverage angle (symmetrical)	80° x50°		/

Amplifier

Amplifier	Class D		
Maximum output power	1600W	2000W	
Frequency response	20Hz-20kHz(±1dB)		
Protection	DC, short circuit, overheating, input and output overload, soft start, overvoltage and undervoltage protection		
Cooling	Air convection		

Back panel

processor	96KHz signal sampling frequency, 24bit quantization accuracy		
Signal input	2x female XLR input (6.35 three core), Bluetooth, 3.5mm three core	Female XLR input	
Signal output	1x male XLR output		
Presets	/	80Hz,100Hz,120Hz	
Power input	IEC female connector		
Working voltage	100V-240V 50Hz/60Hz	100V-130V 50Hz/60Hz 220V-240V 50Hz/60Hz	

Cabinet

Monitor angle	Symmetrical 45° monitoring angle		/
Pole mount gear	35mm mounting hole		
Cabinet material	New polypropylene composite material		CNC made of excellent wood
(WxHxD)Dimensions	345x610x352mm	417x702x426mm	510x632x695mm
Net weight	14.0Kg	17.5Kg	45.0Kg

Drawings

