

# MEDELI

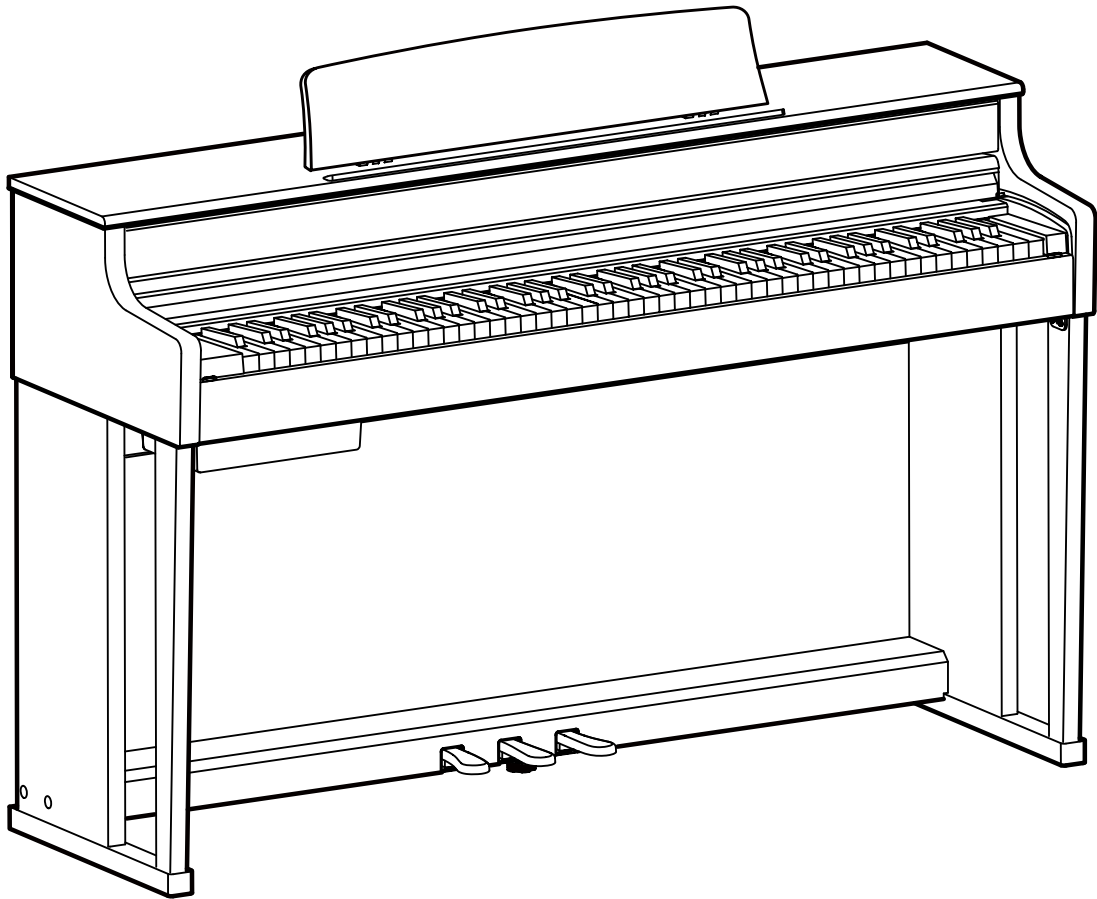

## UP405E

UPRIGHT PIANO  
OWNER'S MANUAL

# Important Messages

Please read this page carefully before operating and keep this manual properly for convenient reference in the future.

## THE FCC REGULATION WARNING (for USA)

This equipment has been tested and found to comply with the limits for a Class B digital device, pursuant to Part 15 of the FCC Rules.

These limits are designed to provide reasonable protection against harmful interference in a residential installation. This equipment generates, uses, and can radiate radio frequency energy and, if not installed and used in accordance with the instructions, may cause harmful interference to radio communications. However, there is no guarantee that interference will not occur in a particular installation. If this equipment does cause harmful interference to radio or television reception, which can be determined by turning the equipment off and on, the user is encouraged to try to correct the interference by one or more of the following measures:

- Reorient or relocate the receiving antenna.
- Increase the separation between the equipment and receiver.
- Connect the equipment into an outlet on a circuit different from that to which the receiver is connected.
- Consult the dealer or an experienced radio/TV technician for help.

Unauthorized changes or modification to this system can void the user's authority to operate this equipment.

## CAUTION

The normal function of this product may be subject to strong electromagnetic interference. Should the circumstances arise, please follow the relevant instructions in this manual to restore the product to its default settings. Otherwise, try moving the product to another location.

## Power supply

Please connect the power adapter provided in the package to a power socket with the correct voltage. DO NOT connect to power sources with unmatched voltages. Unplug this device during thunderstorms or when the device is not in active use.

## Connections

Power off all devices before making connections. This will effectively prevent potential malfunctioning & damage.

## Precautions

To avoid deformation, discoloration or other more serious damages, DO NOT place this instrument in:

- direct sunlight
- extremely hot environments or too close to a heat source (such as a heater)
- severe cold such as snowy and icy outdoors
- dusty environments, or places with high temperatures, high humidity, or unstable locations where strong vibrations or displacements may occur
- proximity of strong electromagnetic fields

## Interference

To avoid unwanted interference, please keep this instrument at a proper distance from televisions, radios, and cell phones.

## Maintenance

Use only soft, dry cloth for cleaning. DO NOT use thinners, solvents, detergents, or wipes soaked with chemicals. DO NOT apply excessive force when handling switches & knobs.

This instrument is safe for use in tropical climates with a maximum operating temperature of 45°C.

The maximum operating altitude is determined by the selected model of the power adapter.

## Handling

Please avoid getting scraps of paper, metal, or other materials inside this instrument. If this happens, unplug this unit and have it checked by a qualified maintenance personnel.

Also, unplug this unit before moving it to another location.

# Contents

<b>Important Messages</b>	2	<b>Song Mode</b>	22
<b>Overview</b>	4	Demos for Grand Piano Sounds	22
Control Panel	5	Demos for Other Instrumental Sounds	22
Display	5	Classical & Lesson	23
Interface	6	Playing One Hand at a Time	23
Connecting Power	7	Play to Search Feature	24
		Playback via USB Drive	25
<b>Preparing to Play</b>	7	<b>Recording Performances</b>	26
Opening and Closing the Keyboard Cover	7	Recording MIDI Sessions to This Instrument	26
Powering On/Off	8	Recording MIDI Sessions to an External USB Drive	27
The Music Stand	8	Recording Audio Sessions	28
Adjust the Master Volume	8	Other Solutions for Recording Audio/Videos	29
Connecting Headphones	8		
Using Pedals	9		
<b>Using the Control Panel</b>	10	<b>Miscellaneous Settings</b>	29
Entering Modes	10	Part Settings—Part Volume	29
Accessing Function Settings	10	Song Settings—Volume and Loop Mode	29
Activating/Deactivating Functions	11	Metronome Settings	30
Quick Accessing Function Settings	11	Recording Format Settings	30
Other Operations	12	USB Format	31
<b>Piano Mode</b>	13	<b>Function Menus</b>	31
Piano Mode	13	Performance Settings	32
Piano Effects	13	An Introduction to Classical Temperaments	33
		Global Effect Settings	34
<b>Sound Mode</b>	16	Display Settings	35
Select and Play Your Sound	16	Power Settings	36
Play Two Sounds Simultaneously (Layered Mode)	16	MIDI I/O Settings	36
Play Different Sounds with Each Hand (Keyboard Split)	17	System Settings	37
Combine Layered Mode and Keyboard Split	17		
Adjust the Overall Brilliance	18	<b>Troubleshooting</b>	39
Turn the Metronome On/Off and Adjust Tempo	18		
Using Transpose	19	<b>Specifications</b>	40
<b>Twinova Mode</b>	20	<b>Appendices</b>	
Activate via the Function Selection Menu	20	Sound List	42
Switch to Twinova from Piano Mode	21	Sound Demo List	43
Pedals in Twinova Mode	21	Classic List	44
Twinova Octave	21	Lesson List	46
		MIDI Implementation List	47

# Overview

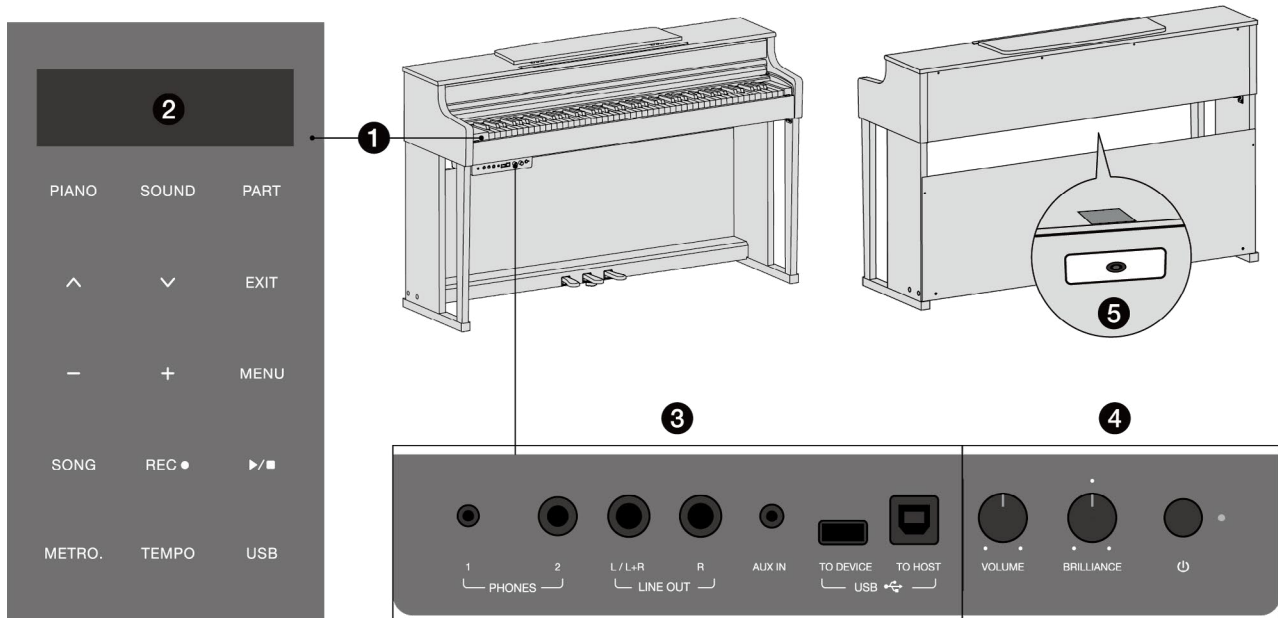

## 1. Control Panel

For accessing sub-menus, adjusting settings and changing parameters.

## 2. OLED Screen

For displaying the current sound, playback title, modes, status of connections and other relevant information.

## 3. I/O (Input/Output) Interface

For connecting external devices.

## 4. Global Control Interface

Include the [POWER] button, the [BRILLIANCE] knob and the [VOLUME] knob.

## 5. DC-In

For connecting the power adapter.

## Control Panel

This instrument features a capacitive touch panel that illuminates when the instrument is powered on. This touch panel allows you to perform various operations by pressing the touch buttons.

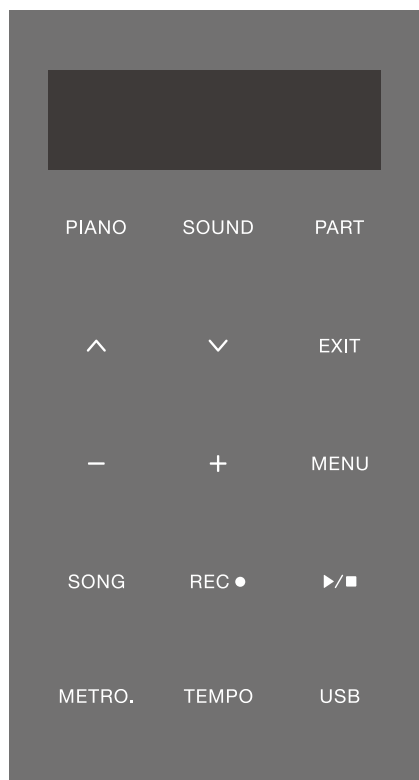

[PIANO]	Enter Piano mode with two grand piano sounds Press to switch between the sounds
[SOUND]	Enter Sound mode Press to switch between available sounds
[PART]	Enter Twinova mode from Piano mode Access the part combination menu in Sound mode
[^] [v]	Switch song categories, sound part combinations, function items, etc.
[−] [+]	Switch between sounds/songs Adjust function options/parameters
[EXIT]	Exit current mode or return to the previous menu
[MENU]	Access the function selection menu Hold down and press other buttons to access specified sub-menus
[SONG]	Enter Song mode
[REC ●]	Enter/quit the recording preparation state when recording as MIDI (page 26, 27), or start recording as audio (page 28)
[▶/■]	Start, pause/stop, or start recording as MIDI
[METRO.]	Turn the metronome on or off
[TEMPO]	Enter the tempo/tempo marking setting to adjust tempo
[USB]	Enter the USB directory to play files stored on a connected USB drive

## Display

The OLED display is located above the touch panel and shows various information relevant to the current mode or function, including the current sound, current song, mode, function, parameter, and connection status. Here are some examples:



Mode page	Top: current sound part, sound number, transpose, tempo Middle: current sound name Bottom: bar & beat number, recording status, time signature
Function menu	Top left: function category Left: current function Right: option or parameter value

For more detailed information on the displays for each mode and function, please refer to their respective sections.

## Interface



### 1. [PHONES] (1&2)

For connecting headphones. (Page 8)

Attention: Avoid high volume for long periods to prevent fatigue or hearing damage. When connected, the instrument's built-in speakers will be muted.

### 2. [LINE OUT] (L/L+R, R)

For connecting to external devices such as stereo speakers, stage monitors, mixing consoles, recording interfaces, etc. Additional audio cables are required to connect to aux/line-out jacks on such devices. Avoid connecting [LINE OUT] jacks to the [AUX IN] jack on this interface, as this will create a feedback loop that may potentially damage the instrument.

### 3. [AUX IN]

For connecting an external playback device such as an MP3 player. Additional audio cables are required to connect to aux/line-out jacks on such devices. External audio will be played through built-in speakers along with the sound of the instrument itself.

### 4. [USB TO DEVICE]

For connecting a USB drive to store recorded sessions in real-time and to play backing MIDI or audio files. MP3, WAV, and SMF formats are supported for both recording and playback. (M4A format supports playback only)

Recorded sessions will be saved in the root directory of your USB drive.

### 5. [USB TO HOST]

For connecting to a PC or a mobile device (converter may be required for the latter).

Supports two-way data transmission for playing back audio files through the instrument's speakers and recording performance without external sound cards.

### 6. [VOLUME] Knob

For adjusting the instrument's overall volume.

### 7. [BRILLIANCE] Knob

For adjusting the level of Brilliance, a tonal characteristic that affects the brightness or darkness of the piano sound. (Page 18)

Turn clockwise for a brighter, more luminous tone, and counter-clockwise for a darker and mellower tone.

### 8. [POWER] Button

Push to turn the instrument on and off.

## Connecting Power

The DC-IN jack is located on the back of the instrument's main body and can be identified by this sticker.

Plug the DC adapter into the DC-IN jack on the rear panel of the instrument before connecting it to a power socket with the appropriate voltage.

Attention,

Please be sure to use the standard adapter that comes with the package! Using a non-standard adapter may cause malfunctions or permanent damage to this unit, or even pose safety hazards.

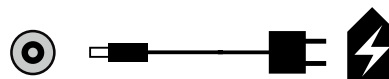

## Preparing to Play

### Opening and Closing the Keyboard Cover

Gently lift the keyboard cover, then push and slide it to the end.

Caution!

Be careful not to injure your fingers.

Please avoid using excessive force when lifting the keyboard cover, as this may cause deformation or scratch.

Do not place small objects, such as paper or pens, on top of the keyboard cover. Small objects placed on the keyboard cover may fall inside the instrument when the cover is opened.

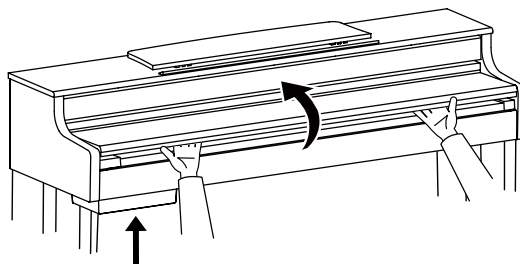

### Powering On/Off

1. Before powering on the instrument, ensure that the standard power adapter is properly connected. Set the volume of the instrument and all connected devices to 0.
2. Press and hold the [POWER] button until the power indicator lights up to power on the instrument. To power off, follow the same procedure until the power indicator goes out.

#### ■ Auto Power Off

To conserve energy, the instrument is designed to automatically turn off after 15 minutes of inactivity.

You can customize this function or turn it off entirely in the Power settings (page 36).

Please note that the instrument may consume more power when this function is disabled.

When the instrument automatically turns off, you can turn the power back on.

Power consumption after the instrument automatically turns off (OFF mode): < 0.3W (less than 0.3W).

Note,

Only use the standard adapter provided with the product to avoid any damage to the unit or safety hazards. Do not use the instrument in thunderstorms or similar environments for safe use of electricity.



## The Music Stand

Gently raise the music stand toward the keyboard, to allow the metal support at the back to naturally pop out. Now you can use the music stand to place sheet music or tablet on it.

When you wish to close the music stand, fold back the metal support, then gently lower the music stand all the way down.

Attention,

Please avoid placing objects on the stand that are too long, too wide, or too heavy for extended periods of time, as this could cause irreversible damage.

Please avoid placing heavy objects on the closed stand for extended periods of time.

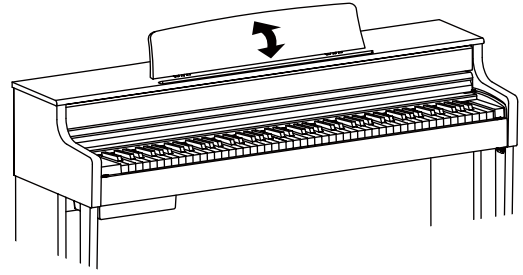

## Adjust the Master Volume

You can adjust the master volume of the instrument by turning the [VOLUME] knob: Turn counter-clockwise to decrease, turn clockwise to increase.

### ■ Dynamic Acoustic System (D.A.S.)

This instrument is imbued with a powerful dynamic effect called the Dynamic Acoustic System (D.A.S.), which equalizes higher and lower frequency bands in loud and quiet sessions, respectively, creating balanced auditory experience in general.

The D.A.S. effect is enabled by default, but you can turn it off in the Global Effect settings (page 35).

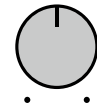

VOLUME

## Connecting Headphones

The instrument has 2 headphone jacks (page 6) available, allowing you to connect two pairs of headphones at the same time. Once headphones are plugged in, built-in speakers will be automatically muted, and you will hear only through the headphones.

Attention,

You may need additional adapters to connect your headphones, and the built-in speakers will stay muted even if adapters are plugged in without headphones.

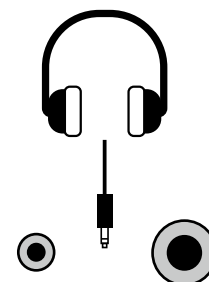

1 2  
PHONES

## Using Pedals

### 1. Left/Soft Pedal

This pedal produces a soft effect on notes played after pressing it down, with a slight decrease in volume and a subtle change in tone. It does not affect notes played before the pedal is pressed down. The function of this pedal varies depending on the selected instrumental sound. For instance, when playing an organ-based sound, it switches rotary speaker speeds.

### 2. Mid/Sostenuto Pedal

Press and hold this pedal while holding notes down to sustain those notes. The sustain will last until you release the pedal. Notes played after pressing down this pedal are NOT affected.

### 3. Right/Damper Pedal

Press and hold this pedal to add a sustain effect to all notes.

#### ■ Progressive Response Grand Piano Pedals

By detecting and responding to pedaling pressure and depth, the instrument's pedals replicate the acoustics of grand pianos to reflect the length of sustain and various other effects associated with the pedal system, hence naturally enhancing your performance.

The damper pedal is also designed to be a half-damper pedal to the likeness of grand pianos. In other words, there is a damping structure that renders the point of half-pedaling more easily felt while pressing down. There are multiple dampening levels as well, which make pedaling feel more natural and comfortable.

#### ■ Adjusting Support Bolts

Before playing for the first time, adjust the support bolts under the pedals to ensure that the bottom ends of these bolts are fully attached to the ground, so that each pedal can properly withstand the force of pedaling. Leaving support bolts mid-air can make pedaling feel unsteady and may even cause damage to pedal bases.

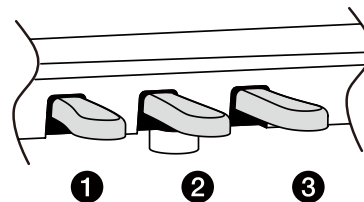

Press the mid/sostenuto here to sustain the F note. Notes played afterwards are not affected.



Press the right/damper pedal here to gain sustain for the F note and all that follows.

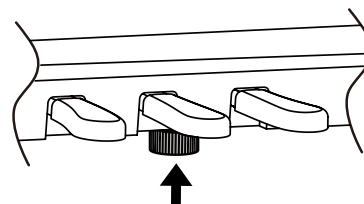

# Using the Control Panel

This instrument features a touch panel for easy operation. By pressing a single button or a combination of two buttons, you can access most of the commonly used functions.

For more advanced operations and detailed settings, please refer to later sections of this manual.

## Entering Modes

You can enter/switch to certain modes by pressing specific buttons:

- Press the [PIANO] button to enter the Piano mode.  
Once you are in, you can switch between two grand piano sounds by pressing [PIANO], [▲] / [▼], or [-] / [+].
- Press [SOUND] to enter the Sound mode.  
From there, you can press [▲] / [▼] to switch between sound parts.  
Then switch the sound for the current sound part by pressing [SOUND] or [-] / [+].
- Press [SONG] to enter Song mode.  
Then, press [-] / [+] to switch between songs in the current category;  
press [SONG] or [▲] / [▼] to switch the song category.  
Hold down [SONG] to activate the Play to Search feature (page 24).



## Accessing Function Settings

You can access certain functions by pressing specific buttons.

- In Sound mode, press [PART] to access the sound part combination menu. Then use [▲] / [▼] to switch between combinations.
- Press [MENU] to enter the function selection menu.  
Then press [MENU] to switch function category;  
press [▲] / [▼] to switch between function items in the current category;  
press [-] / [+] to adjust the selected item's option or parameter.
- Press [TEMPO] to enter the tempo/tempo marking setting.  
Press [-] / [+] to adjust the speed;  
press [▲] / [▼] to switch between BPM and tempo marking. (Page 18)
- Press [USB] to access the USB directory page.

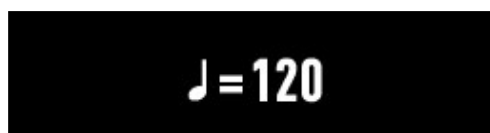

## Activating/Deactivating Functions

You can instantly activate/deactivate certain operations or features using these buttons:

- Press [REC ●] to enter/quit the recording preparation state when recording as MIDI (page 26, 27). Press to start or stop recording when recording as audio (page 28).
- Press [▶/■] to start, pause/stop playback; to start recording as MIDI while in the recording preparation state.
- Press [METRO.] to activate/stop the metronome.



## Quick Accessing Function Settings with Button Combinations

You can quickly access certain function or mode settings by holding down [MENU] and pressing another button.

- [MENU] + [PIANO]: Piano Effects Setting
- [MENU] + [PART]: Part Setting
- [MENU] + [SONG]: Song Setting
- [MENU] + [METRO.]: Metronome Setting
- [MENU] + [REC]: Record Setting



- [MENU]+[USB]: USB Setting (file system format)



You can also hold down [SONG] and press other buttons to put on specified playbacks.

- [SONG]+[SOUND] to put the demo of the current sound on playback.



## Other Operations

- Reset  
Press [-] & [+] simultaneously to reset the current function's option or parameter to default.
- Hold [-] / [+] to speed up adjustment.  
Hold [^] / [v] to speed up switching between categories or functions.
- Exit  
Press [EXIT] to exit modes, menus or sub-menus.

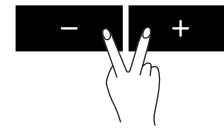

Attention,  
The touch panel will automatically shut down and turn off all button lights after being idle for a certain period of time. Simply touch anywhere on the panel to regain control.  
The instrument features a slight feedback sound upon pressing any active buttons. This can be turned off in the System settings (page 37).

# Piano Mode

This instrument features two concert grand piano sounds, enabling you to select based on your personal preference or to best complement the style of the piece you wish to perform.

In the Piano mode, which we highly recommend, the two grand piano sounds are brought to full with realistic piano effects and ambience simulations, providing a more immersive and authentic experience as you play.

## Piano Mode

1. Press [PIANO] to enter the Piano mode.

2. Now you can play!

Note that the spectrum of your performance is automatically animated and displayed on the screen. This is done to help extend the lifespan of the screen by preventing static images from being displayed for extended periods of time.

The instrument's default sound is "Concert Full X Grand". To switch to the other piano sound, press [PIANO] , [^] / [v] or [-] / [+].

Press [EXIT] to quit the Piano mode.

A black rectangular box with the text "Concert Full X Grand" in white, bold, sans-serif font.

## Piano Effects

This instrument uses advanced digital technology based on sample modeling called FSM (Free Strings Modeling) to simulate natural and realistic piano effects.

For acoustic pianos, pressing down key(s) will raise the damper(s) from the string(s), allowing them to vibrate freely and resonate with each other. And when the damper pedal is pressed down, all the dampers are raised from the strings, causing even the strings that have not been struck by the hammer to resonate with those that have.

The FSM technology simulates this effect by allowing the free strings to vibrate naturally and extend to a full overtone resonance when additional notes are played, or the damper pedal is pressed down while holding down notes. This creates subtle and/or glorious sounds.

You can switch options or adjust parameters of the FSM and ambience effects to obtain rich and unique sounds for your piano performance.

Hold down [MENU] and press [PIANO] to enter the Piano effects settings.

Press [^] / [v] to switch effects and press [-] / [+] to change options or adjust parameters. Press [EXIT] to quit.

Note that each grand piano sound has its own set of effects. Changing settings of one sound does not affect the other sound.



## Effect List

- **Damper Resonance** *FSM*  
 Simulate the string resonance effect when playing additional notes after pressing down the damper pedal.  
 Adjust to set the degree of resonance.

Parameter	Default
0~10	5

- **Damper Noise**  
 Simulate the physical noise generated by the movement of the damper pedal and string dampers while pedaling.  
 Adjust to set the audibility of the noise.

Parameter	Default
0~10	0

- **String Resonance** *FSM*  
 Simulate the strings' overtone resonance produced by pressing keys successively.  
 Adjust to set the degree of overtone resonance.

Parameter	Default
0~10	5

- **Lid Angle**  
 Simulate the different angles of the top lid.  
 Change the option for a more closed or open sound.

Parameter	Default
Close / Half / Open	Half

- **Open String Resonance** *FSM*  
 Simulate the open string resonance in the treble range area which is always unrestrained.  
 Adjust to set the degree of resonance.

Parameter	Default
0~10	5

- **Key Off Effect**  
 Simulate the sound effect of the damper gradually lowering back onto the strings as the keys are released.  
 Adjust to set the audibility of the sound effect.

Parameter	Default
OFF,Low,Normal,High	Normal

- **Soft Pedal**  
 Adjust to set the depth of the left/soft pedal's effect.

Parameter	Default
0~10	5

■ **Ambience**

This instrument offers several simulated ambience types with unique reverbs for live performances:

**Room:** Simulates a smaller, intimate domestic indoor space with no special acoustic treatments. The restrained, soft reverb is ideal for creating a warm and personal sound.

**Saloon:** Simulates a larger indoor space with no special acoustic treatments. The clear and elegant reverb is suited for a wide range of musical styles and genres.

**Chamber:** Simulates medium-sized halls used for public performances of chamber music, art song, and solo. The full and bright ambience type can enhance the clarity and projection of your playing.

**Symphony hall:** Simulates large concert halls for symphonic music. The thick, brilliant, and long reverb can add depth and resonance to your playing.

**Church:** Simulates cathedrals with high roofs. The ethereal and solemn reverb can create a majestic and reverential atmosphere.

**Club:** Simulates clubs with clean and tight reverb best suited for indoor live performances.

Option	Default
Room / Saloon / Chamber / Symphony hall / Church / Club	Chamber

■ **Ambience Depth**

This effect simulates the size of space in which you are performing. Adjust to set the size of the currently selected environment to obtain different depths and characteristics for your sound.

Parameter	Default
0~10	5

■ **Body Resonance**

Simulate the slight resonance generated from within the piano's cabinet. Adjust to set the degree of resonance.

Parameter	Default
0~10	5

# Sound Mode

In Sound mode, you have access to a variety of other instrument sounds besides the generic piano sounds. For more information about all the available sounds, please refer to the Appendix section (page 42).

## Select and Play Your Sound

1. Press [SOUND] to enter Sound mode.
2. Press [SOUND] again or [-] / [+] to switch between sounds.  
You can also hold down [SONG] and press [SOUND] to display the demo of your current sound, then press [▶/■] to put it on playback.

When playing different sounds, the function of the left/soft pedal adapts to the characteristics of the instrument to which your sound corresponds. Check the list in the Appendix section (page 42) for more information. You might notice that certain sounds are not touch-responsive, as their corresponding instruments are not touch-responsive in the first place.



## Play Two Sounds Simultaneously (Layered Mode)

You can layer two different sounds simultaneously allowing for a wide range of timbral combinations and creative possibilities.

1. Press [PART] to enter the part combination menu.  
Use [^] / [v] buttons to switch the combination to "R1-ON, R2-ON".  
Note that "R1" will always be "ON" regardless of your choice.  
Now play a note and you should hear two instrument sounds.
2. To select sound for "R2", press [EXIT] to return to Sound mode.
3. Here, you can press [^] / [v] to switch to "R2".
4. Press [-] / [+] buttons to select a desired sound for "R2".  
Then switch back to "R1" and repeat the same.



If you need to adjust the volume for each sound part, you can hold down [MENU] and press [PART] to access Part Setting (page 29) where you can set the volume for "R1" and for "R2".

## Play Different Sounds with Each Hand (Keyboard Split)

You can split the keyboard into two separate sections, left and right. The key where the keyboard splits is called the “split point”. Different sounds can be assigned to each section, allowing you to play one sound with one hand, and another sound with the other hand.

1. To split the keyboard, go to the part combination menu and switch to “R1-ON, L-ON”.
2. You can manually set the split point which is the highest note of part “L” (the left/lower-octave area). In the part combination menu, press [–] / [+] to adjust the split point’s location. Or you can hold down the [PART] button, then press a desired key to designate it as the new “split point”.  
You can reset the split point to F#3 by pressing [–] and [+] simultaneously.

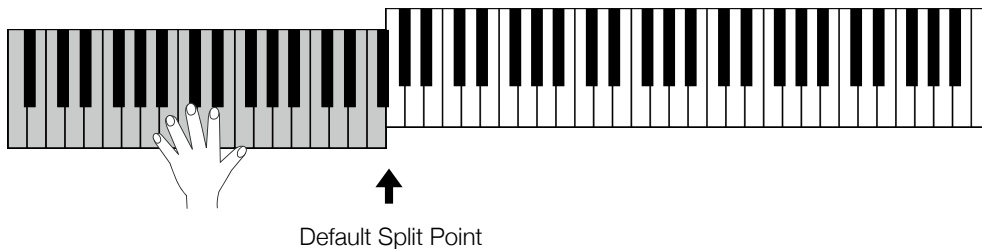

3. To select a desired sound for “L”, press [EXIT] button to return to Sound mode.
4. Press [^] / [v] to switch to “L”, then press [–] / [+] to select the sound you want. Repeat the same for “R1”.  
As mentioned, you can access the Part Setting (page 29) and adjust the volume for each part as you see fit.

## Combine Layered Mode and Keyboard Split

You can enable Layered mode and keyboard split simultaneously by enabling all three sound parts: Part “R1” and “R2” for the right-hand area, and the low-octave part “L” for the left-hand area. To do so:

1. Switch the part combination to “R1-ON, R2-ON, L-ON”.
2. Press [EXIT] to return to Sound mode.
3. Press [^] / [v] to switch parts, then press [–] / [+] to select a desired sound for each of them.  
As mentioned, you can access Part Setting (page 29) to adjust the volume of each part.



## Adjust the Overall Brilliance

You can use the knob on the I/O interface to adjust the overall degree of Brilliance.

Turn clockwise to emphasize treble, giving the sound a brighter, more luminous tone.

Turn counter-clockwise to emphasize bass for a darker and mellower tone.

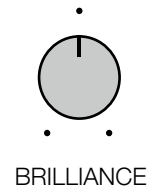

## Turn the Metronome On/Off and Adjust Tempo

The metronome can help you improve rhythm during practice and keep steady while recording.

To turn the metronome on or off, simply press the [METRO.] button on the touch panel.

By default, the metronome does NOT sound the bell that stresses the first beat of every bar. You can go to the Metronome settings (page 30) to turn the bell on or off, select time signatures or adjust metronome volume.

Once activated, the metronome will produce a clicking sound at a preset tempo. To adjust it:

1. Press [TEMPO] to enter Tempo/Tempo Marking setting.
2. Press or hold [-] / [+] to adjust the speed.

The instrument also includes a helpful cross-reference tool that matches different tempos to tempo markings. If you come across a marking in your score but are unsure of its tempo range, this tool can provide a general reference to help you better understand the intended tempo.

To access this feature, go to the tempo/tempo marking setting and press [^] / [v] to switch to the tempo marking that corresponds to for the current tempo. Then press the [EXIT] button to return to Sound mode, and you should see the marking at the top-right corner, replacing the BPM.

Attention,  
Tempo marking provides only a general reference. The actual tempo should be adjusted to suit the unique flow of the score being played. Also, the beats will NOT be recorded, so you can always have the metronome on or off as you see fit.

METRO.

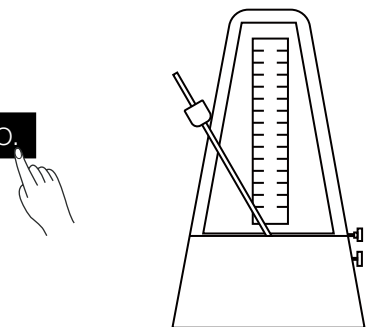

**$\text{♩} = 120$**

**Animato  $\text{♩} = 120$**



**R1 01** Animato  
**Concert Full X Grand**  
001:01 4/4

## Using Transpose

Transposing allows you to shift the pitch of the entire keyboard in semitones. By doing so, you can sound like you are in a different key without actually changing your finger placement. This feature is particularly handy for accompanying a singer or playing with other tonal instruments.

For instance, setting the transpose value to “1” will raise any notes played on C by a semitone to C#. Alternatively, if you need to play in the key of G but are unfamiliar with its scales, you can set the transpose to “-5” or “7” to be able to sound like you are in the key of G by actually playing scales in the key of C.

The device supports  $\pm 12$  semitones range for transposing, which applies only to notes played on keyboard and does NOT affect built-in songs.

1. Press [MENU] to go to the function selection menu, then press [^] / [v] to switch to “Transpose”.
2. Press [-] / [+] to shift down/up the entire keyboard by semitones. Press [-] and [+] simultaneously to reset to 0.
3. Press [EXIT] to quit the function selection menu.

Attention,

Certain sounds may sound unusual at the maximum transpose level (“+12/-12”) since their range has been significantly increased or decreased beyond the range of their corresponding instruments.



# Twinova Mode

In this section, we would like to show you the Twinova mode, in which the entire keyboard is divided into two equal areas, left and right, with the same pitch and sound for both. This feature is particularly useful for elementary level one-on-one instruction, as well as for practicing and performing simple duets that require two pianos. You can activate Twinova mode in two ways.

## Activate via the Function Selection Menu

1. Press the [MENU] button to enter/display the function selection menu. Press [^] / [v] to switch to "Twinova"
2. This mode is disabled by default. Press [+ ] to switch it on.
3. Press [EXIT] to quit the function selection menu. Now you are in Twinova mode, and the screen should display a duo piano interface as well. You can quit the Twinova mode by pressing [EXIT] or [SOUND].



The split point for this mode is at E4 (which is the highest note in the left area). And the entire keyboard's pitch has shifted as follows:

- The left area (originally A0~E4) is now A2-E6
- The right area (originally F4~C8) is now F2-C6

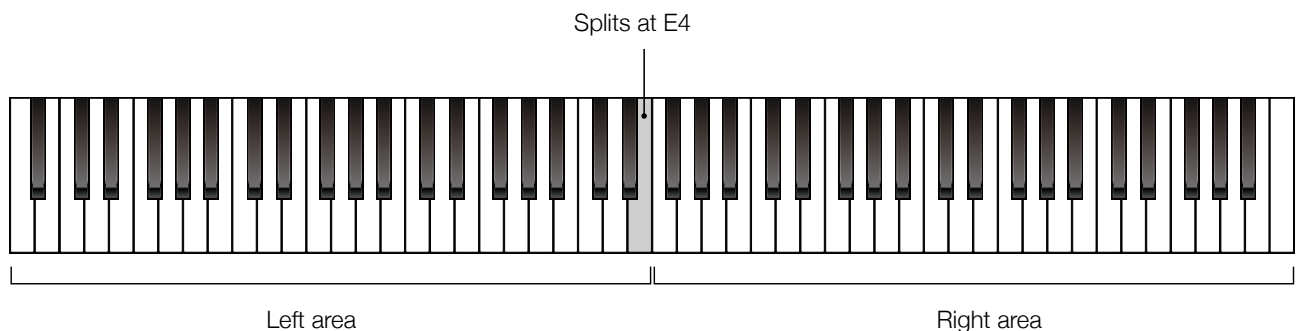

The mode only supports the two grand piano sounds, and the name of the current sound is displayed at the top left-hand corner. Press [PIANO] to switch to the other one if needed.



To quit the mode, you can either go to the function selection menu, switch to Twinova and turn it off. Or you can simply press [PART] while in Twinova mode: This will take you back to Piano mode where you can immediately perform full-keyboard solos.

## Switch to Twinova from Piano Mode

1. To switch to Twinova from Piano mode, simply press the [PART] button.  
Note that the sound you previously selected for Piano mode will also be carried over to Twinova mode.
2. Once in Twinova mode, you can switch between the two piano sounds by pressing [PIANO]. To return to Piano mode, press [PART] again.



## Pedals in Twinova Mode

In Twinova mode, all three pedals function as damper pedals, each controlling a different keyboard area:

- The left pedal controls the lower-octave area
- The right pedal controls the higher-octave area
- The middle pedal controls the full keyboard

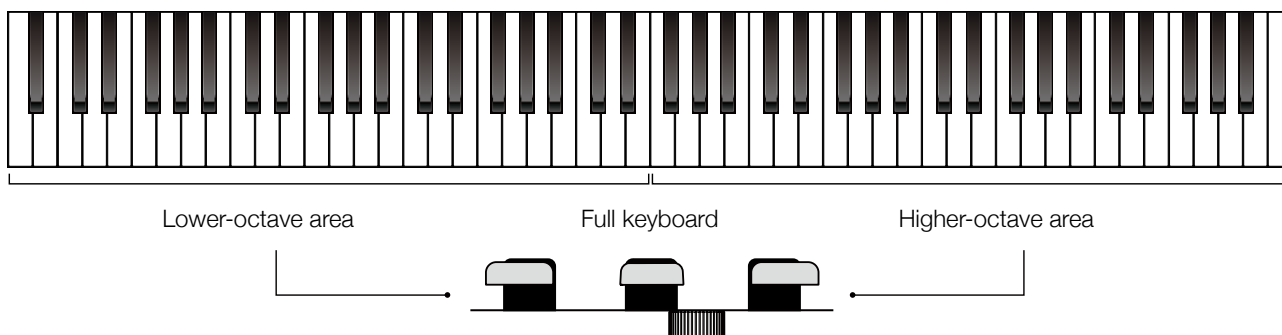

## Twinova Octave

You have the option to transpose one octave up or down in Twinova mode. To do so:

1. Press [MENU] to enter the function selection menu, then press [↶] / [↷] to switch to Twinova Octave.
2. Press [-] / [+] to transpose one octave down or up. Note that only one full-octave is allowed for transposing, as in "-1" ~ "+1".
3. Press [EXIT] to return to Twinova mode where you will see a number indicating the octave you just set.  
This feature is effective ONLY for Twinova mode.



Attention,

Upon switching to Twinova mode, any semitone-transpose value previously applied in other modes will be reset to 0. If you wish to transpose semitones in Twinova mode, you can do so via the function selection menu (page 19), and the transposing value you set will be carried over to other modes.

# Song Mode

This instrument comes with a large selection of built-in tracks, mainly classical piano masterpieces and tutorial lessons suitable for learning and practicing. For full lists of tracks, please refer to the Appendix section (page 44). You also have the option to mute the left or the right-hand part for certain tracks, allowing you to focus on performing or practicing one hand at a time.

In addition, audio playback in various formats is available by connecting an external USB drive.

There are three categories of tracks:

- Demo (contains 1 group of tracks for grand pianos and other instrumental sounds)
- Classical (contains 1 group of tracks)
- Lesson (contains 5 group of tracks)

## Demos for Grand Piano Sounds

You can access and listen to demos of the two grand piano sounds to study their characteristics and nuances.

1. Press [SONG] to enter Song mode. Press [^] to switch to the “Demo” category.
2. Track 1 and 2 are the demos for grand piano sounds. Press [▶/■] to start or pause the demo.

There are different loop modes as in what order the tracks will loop. Please refer to the Miscellaneous Settings section (page 30) if you want to change the mode.



## Demos for Other Instrumental Sounds

All the other instrumental sounds have demos as well. These demos are accompanied by other instruments rather than solos. You can listen to them to get a sense of how these sounds play out in different styles of music.

1. Hold down [SONG] and press [SOUND] to display your current sound's demo.
2. Once the demo is displayed, press [▶/■] to start or pause its playback.

And as mentioned, you can also press [SONG] to enter Song mode and then switch to the “Demo” category from which you can select a demo and put it on playback.



## Classical & Lesson

The classical category offers a wide range of classical piano pieces by famous composers from various eras. These tracks are great for appreciating and practicing classical repertoires.

1. Press [SONG] to enter Song mode.
2. Press [SONG] or [^] / [v] to switch the category to "Classical".
3. Press or hold [-] / [+] to switch tracks.
4. Press [▶/■] to play or pause the selected track.

This instrument comes with five sets of lesson tracks as well. These are tracks with simpler melodies, moderate tempos and steady rhythms suitable for beginners. Simply switch to the "Lesson" category to access them.

In Song mode, the bpm, time signature and the bar & beat number of the current track are displayed.

You can change the tempo (page 18) during playback.

You can also switch playback loop modes via the Song Setting menu (page 30).

And note that switching to another category will stop the ongoing playback.



## Playing One Hand at a Time

All built-in piano songs (demos not included) feature left and right-hand parts.

You can mute the part you wish to practice and keep the other part audible as accompaniment. For instance, to focus on playing or practicing the right-hand part:

1. First, select the song you want to practice from the "Classical" or "Lesson" category.
2. Hold down [SONG] and press [PART] repeatedly until "L/-" is displayed on screen.

This means that the right-hand part is muted and the left-hand part is audible. Now start the playback and you can practice the right-hand part.

To switch sides, hold down [SONG] and press [PART] repeatedly to:

- Mute right, keep the left-hand part ("L/-")
- Mute left, keep the right-hand part ("-/R")
- Cancel muting and keep both parts ("L/R")

Note that this operation only applies to tracks from the Classical and Lesson categories.

Some particularly simpler tracks in the Lesson category may have additional accompanying parts that can NOT be muted.

This operation can be done during playback.



## Play to Search Feature

With such a vast library of tracks, you may find yourself spending a lot of time flipping through menus for a song you are already familiar with, which can be time-consuming and inefficient. Fortunately, this instrument offers an innovative play-recognition feature using AI technology.

With this feature, you can play a short melody on the keyboard to locate and bring up the corresponding piece within 10 seconds, whether you play the left-hand, right-hand, or both at the same time.

Even if the melody you play is not perfect, the AI will still be able to find the most matching piece accurately.

1. Press and hold the [SONG] button until you hear a beep, which means the feature is now activated. You then have 10 seconds to play a short melody on the keyboard. You can play the left-hand, right-hand, or both during which the instrument detects, analyzes, and remembers your performance.
2. The system will automatically search for the piece you just played from its library.
3. The search result will be displayed shortly.  
If successful, the title and composer of the original piece would pop up. You can then press [▶/■] to display the piece and play it back. Note that the AI will not be able to find a result if you play melodies that are NOT from the built-in library in which case you will be prompted that the search has failed.

It is recommended that you play a clip from the beginning of a piece so that the AI is more likely to come up with an accurate result.

If you come across bits and pieces from classics of which you cannot remember the titles, it is also recommended that you try playing them on this instrument: The AI might have just the answer for you.

Attention,

For accurate Play to Search results, ensure only the “R1” sound part is active. The system will not recognize played melodies with “R2” or “L” enabled.

“Classical 101” at the end of the Classical category is reserved as the user track, which by default is empty. The MIDI sessions you have recorded on this instrument will be saved to this location.



Please play for 10 sec.

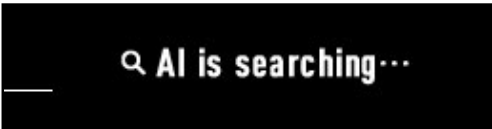

AI is searching...



Hanon 35

Hanon

Press ▶ to listen

## Playback via USB Drive

In addition to tracks from the built-in library, you can also play back files from an external USB drive. The instrument supports FAT32 format USB drives with a storage capacity up to 128 gigabytes. Formats supported include:

- SMF (Standard MIDI Format)
- WAV, MP3, M4A

Follow these steps:

1. Insert a compatible USB drive into the [USB TO DEVICE] jack (page 6) on the I/O interface.
2. Press [USB] to enter/display the USB directory menu. The screen will show information of the first playable MIDI or audio file on the drive.
3. Press [-] / [+] to switch between files.
4. Press [▶/■] to play/pause the selected file.

While playing back files from external drives, you can still play the keyboard and access general functions such as switching sounds. If you want to adjust the volume of the playback to match your performance, hold down [MENU] and press [SONG] to access the “Song Setting” menu (page 30).

If the system fails to detect any playable formats on the inserted drive, it will prompt you on screen.

If your USB flash drive does not function properly, it may be because its file system format of the drive itself is not supported. In this case, you can hold down [MENU] and press [USB] to access the USB formatting feature (page 31) and press [+] to format the drive to the supported FAT32 format. Please note that this process may take some time to complete, and you will be prompted when it is finished.

Attention,

Formatting the drive will wipe all files and contents completely, so please be sure to check beforehand if there is any content worth keeping to avoid loss of useful data.

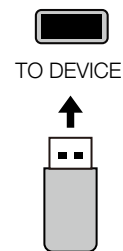

# Recording Performances

This section will show you how to record performances for you to playback or share.

The instrument supports MIDI files (SMF) and audio files (WAV, MP3) for recording. If you do not have an external USB drive connected, you can only record MIDI sessions and save them to the user track slot ("Classical 101"). If you are connected to an external USB drive, your recorded MIDI files will be saved to the drive, which you can later export to host devices such as a computer for further editing or other creative purposes.

To record audio files, you must connect an external USB drive. The device supports high-quality recording in stereo WAV format (44.1kHz/16-bit) and MP3 format (320Kbps), with up to 90 minutes of recording time per session if sufficient storage space is available on the USB drive.

Recording keyboard performances is not the only option. You can also record external audio from the [AUX IN] jack or [USB TO HOST] jack (page 6).

## Recording MIDI Sessions to This Instrument

"Classical 101" is reserved as the user track. If you need to record MIDI files directly to this instrument, make sure that NOTHING, including USB converters, is connected to the [USB TO DEVICE] jack, as the recorded file will go straight to this port if connected.

1. Press [REC ●] to enter the recording preparation state.  
This is where the [REC ●] button starts to blink and a "REC" sign (also blinking) is displayed. The metronome automatically starts clicking at this point as well. If you do not need the clicks, press the [METRO.] button to turn it off. Note that you can turn it back on any time, and the clicking sounds will NOT be recorded in any circumstances.  
  
In the recording preparation state, you can perform various preparations such as switching sounds, configuring part combinations, adjusting tempo, etc.  
Press [REC ●] once more to quit the recording preparation state.
2. After you have done all necessary preparations, the system would automatically start recording as you start playing the keyboard, or you can press [▶/■] to start recording manually.  
You will notice right away that both the [REC ●] button and the "REC" sign stop blinking and remain lit instead, indicating that the recording is now in progress.
3. When finished, press [REC ●] to immediately stop recording and save the session as the user track ("Classical 101").  
The screen would automatically display the saved session upon finishing, so you can immediately press [▶/■] to put it on playback and have a listen.



You can record MIDI sessions in Piano mode, Twinova mode and Sound mode whenever you want by following the above procedures.

If there is a previously recorded session stored in “Classical 101”, you will be asked if you want to overwrite it when you try to record a new session. To abort the process, press [-]. To continue to the recording preparation state, press [+]. Your new session will overwrite the previous one should you choose to proceed.

If you do not wish to overwrite your saved session, you can connect a USB Drive to record directly to the external storage.

Due to limited built-in storage space, the recording process will terminate once the file size exceeds a certain point.

## Recording MIDI Sessions to an External USB Drive

When connected to a USB drive, your sessions will be saved to it by default. To get started, connect the USB drive to the [USB TO DEVICE] jack (page 6) on the I/O interface and make sure it works properly.

1. Press [REC ●] while holding [MENU] to access the “Record Setting” menu.
2. Press [-] / [+] to set the recording format to MIDI and press [EXIT] to quit.
3. Press [REC ●] to enter the recording preparation state.  
You can press [REC ●] again to quit this preparation state.  
Note: Since your recording will go straight to the USB drive later, a USB icon is prompted next to the “REC” sign. If the icon is NOT displayed, it means that the system has NOT detected the USB drive and will save your session to “Classical 101”.
4. When you are done with all preparations, play the keyboard or press [▶/■] to start recording.
5. When finished, press the [REC ●] button to stop recording immediately.  
This will save the session you just played directly onto the USB drive.

All recorded sessions will be saved in the root directory of your drive. The screen would automatically display the recorded track upon finishing, so you can immediately press [▶/■] to have a listen.

If a USB drive is connected, newly recorded MIDI files will NOT overwrite the previous ones. Instead, they will be saved as new files on the drive with incrementally numbered filenames.

Note that if the connected USB drive runs out of space during a recording session, the system will prompt you and proceed to terminate and save the current session. We recommend reserving enough space on the drive before starting long recording sessions.

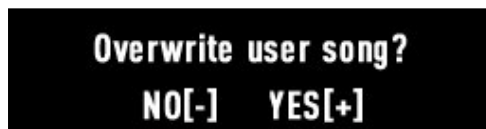

If your MIDI session is recorded in Piano mode, you might notice a loss of certain piano effects. This is because certain effect simulations can only be achieved through the instrument's hardware technology and are not meant to be compiled to MIDI signals. To obtain the best recording result in Piano mode, we recommend you record as audio.

## Recording Audio Sessions

If you wish to record keyboard performance as audio files such as WAV/MP3, you can only do so by connecting a USB drive to the [USB TO DEVICE] jack (page 6). Note that you can also record your performance along with inputs from the [AUX IN] jack or [USB TO HOST] jack (page 6).

Before you start, connect a USB drive to the [USB TO DEVICE] jack (page 6) and make sure it works properly.

1. Hold down [MENU] and press [REC ●] to enter the "Record Setting" menu.
2. Press [←] / [→] to set the format to WAV or MP3. Press [EXIT] to quit the menu.
3. Press [REC ●] to start recording immediately.  
All sounds made by this instrument (excluding the metronome clicks) will be captured as audio.
4. Press [REC ●] when finished to stop recording and save the session to the connected USB drive.  
All recorded sessions are saved in the root directory of your drive. The screen would automatically display the recorded audio file, so you can press [▶/■] to play it back instantly.

The instrument supports a maximum of 90 minutes per session, provided that the connected USB drive has sufficient storage space. When the recording reaches 3 minutes remaining, the "REC" sign will blink rapidly until the maximum limit is reached. The system will then automatically terminate the recording and save it to the USB drive.

During audio recording, playback of audio files from the connected drive is not possible.

Playback for MIDI files from the drive however, is possible: You can record audio sessions of yourself performing the keyboard accompanied by MIDI playbacks.

If you need to record rather long audio sessions, we recommend reserving enough space on the drive before you start.

Also, when you are using the 2-way USB audio transfer function (see below) to play back audio from an external PC or smart device, you can record it as audio files to your connected USB drive as well.



## Other Solutions for Recording Audio/Videos

This instrument supports 2-way USB audio transfer.

It can function as a playback device when connected to a computer, smartphone, or other external device via the [USB TO HOST] jack (page 6). This means that audio from external devices can be played through the instrument's speakers.

Additionally, you can use the external device to directly record performances without additional audio interface.

If your external device, such as a smart phone, supports video and audio recording, you can achieve instant video and audio recording using a specified app.

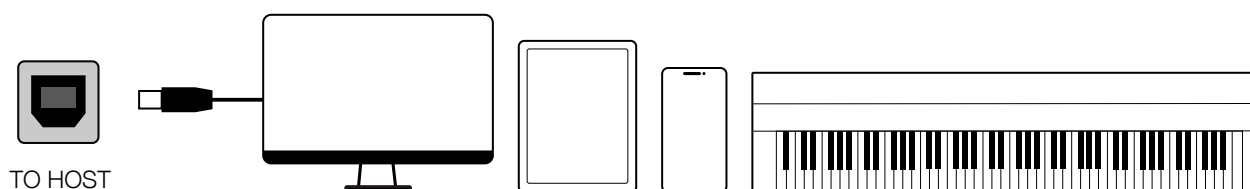

## Miscellaneous Settings

You can access settings for certain functions by pressing specific buttons while holding down [MENU].

To reset a function's option or parameter to default, press [-] and [+] simultaneously.

### Part Settings—Part Volume

The instrument has a maximum of three sound parts (“R1”, “R2”, and “L”) and you can adjust the volume for each separately.

1. Hold down [MENU] and press [PART] to enter the Part Setting menu.
2. Press [^] / [v] to switch to the desired part and press [-] / [+] to adjust its volume.
3. Press [EXIT] to exit the menu when finished.

Setting	Parameter
R1 Volume	0~127
R2 Volume	0~127
L Volume	0~127

### Song Settings—Volume and Loop Mode

You can access the “Song Setting” menu to adjust playback volume or change the loop mode.

1. Hold down [MENU] and press [SONG] to access the Song Setting menu.

Setting	Option/Parameter
Volume	0~127
Loop Mode	Single / All

2. Press [^] / [v] to select the desired setting, then press [-] / [+] to adjust playback volume or change the loop mode.

3. Press [EXIT] to quit when finished.

To loop the current track, choose “Single”. To loop all tracks in the current category, choose “All”.

The volume setting also affects playback from Aux-In.

## Metronome Settings

In this menu, you can select different time signatures, turn on/off the accent bell, and adjust the metronome’s volume.

1. Hold down [MENU] and press [METRO.] to enter the Metronome setting menu.
2. Press [^] / [v] to switch to the desired setting and press [-] / [+] to select time signatures, turn the accent bell on or off, or adjust the metronome’s volume.
3. Press [EXIT] to quit when finished.

For time signatures, the numerator represents the number of notes per bar, and the denominator represents the length of each note. Once set, turn on the metronome and you will hear it clicking in the selected time signature.

Please note that the time signature is subject to change as the system applies corresponding time signatures to different built-in songs. Also, when the time signature shifts within a song, the metronome will correspond accordingly.

Setting	Option/Parameter
Signature	2/2, 2/4, 3/4, 4/4 5/4, 6/4, 7/4, 8/4 9/4, 3/8, 6/8, 9/8 12/8, 12/16
Bell	ON / OFF
Volume	0~127

## Recording Format Settings

The recording format settings depend on whether you are recording directly to the instrument or to an external USB drive.

If you are recording directly to the instrument, the only available format is MIDI. However, if you have an external USB drive connected, you can record both MIDI and audio formats, and all sessions will be saved to your drive.

To select the desired recording format:

1. Hold down [MENU] and press [REC ●] to enter the “Record Setting” menu.
2. Press [-] / [+] to select the format you need.
3. Press [EXIT] to quit when finished.

Setting	Option
USB Record	MP3 / WAV / MIDI

## USB Format

The instrument supports USB drives in FAT32 format with up to 128G storage space. If your connected drive is not working properly, check if it is compatible or try formatting it in the “USB setting” menu.

1. Hold down [MENU] and press [USB] to enter the “USB Setting” menu.
2. Note that the [–] button is unresponsive in this menu.  
Press [+] to proceed and the system will show a warning message.  
Press [+] again to begin formatting the drive.
3. Please be patient as Initialization usually takes some time. The screen will show that the drive is being formatted. Wait until the process is complete and the screen displays a message that the drive has been formatted successfully. If the procedure failed, it is possible that your drive was corrupted in the first place.

After successful formatting, the drive’s directory menu will be displayed, which will be empty since the formatting has just wiped everything.

Attention,

Please be sure to check if there is any content worth keeping on the drive to avoid loss of useful data before the operation.

DO NOT disconnect the USB while formatting is in progress as this may damage the drive!

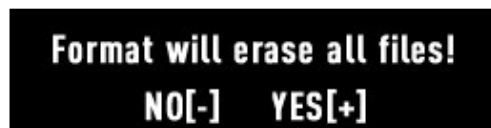

## Function Menus

You can set options and adjust the parameters of various functions in detail by accessing their corresponding sub-menus in the function selection menu.

There are 6 categories of functions: “Performance”, “Global Effect”, “Display”, “Power”, “MIDI I/O” and “System”. To access:

1. Press [MENU] to enter/display the function selection menu.
2. Then press [MENU] repeatedly to cycle through the six function categories.  
When you first enter the function selection menu after turning on the instrument, the first function of the “Performance” category will be displayed. To quickly switch to the first function of the next category, which is the “Global Effect” category, press the [MENU] button again.
3. Press or hold [∧] / [∨] to switch through functions within each category.
4. Press [–] / [+] to set options or adjust parameter of the selected function. Note that you can reset a function’s settings to default by pressing [–] and [+] simultaneously.
5. Press [EXIT] to quit the function selection menu.



## Performance Settings

### ■ Touch Response

When playing the piano, the dynamics, tone changes, and other effects of the notes are controlled by the force of your touch. The touch response feature is enabled by default to ensure your emotional expressions are well reflected.

You have the option to disable it, resulting in the same volume produced no matter how much force you use.

This instrument comes with 5 levels of touch response curves from which you can choose to best suit your style. Should you choose “Soft”, you will find it easier to play louder notes; choose “Hard” and you will be needing extra force.

Note that certain sounds, such as harpsichords, are not touch-responsive even with this feature enabled, due to their inherent characteristics.

Function	Option	Default
Touch Response	OFF / Soft 2 / Soft 1 / Normal / Hard 1 / Hard 2	Normal

### ■ Fixed Velocity

When the touch response is set to “OFF”, you can set a consistent velocity for the entire keyboard.

Please note that this setting is only applicable when the touch response is off. When using any of the five available touch response curves, the instrument will respond to varying levels of velocity, and the fixed velocity parameter will be displayed as “-” and will not be adjustable.

Function	Parameter	Default
Fixed Velocity	1 ~ 127	---

### ■ Transpose

Transposing (page 19) allows you to move the pitch of the entire keyboard in semitones. This means you can shift to a different key without changing how you play. This is a very handy feature when you need to accompany a singer or play with other instruments that are in a different key. The feature has NO effects on built-in playbacks.

Function	Parameter	Default
Transpose	-12 ~ +12	0

### ■ Master Tune

Master Tune can globally adjust the pitch of the entire instrument in cents. This function can be used to match the tuning of other instruments when needed.

Function	Parameter	Default
Master Tune	415.4Hz ~ 466.2Hz	440.0Hz

### ■ Classical Temperaments

Temperament is a tuning system that precisely regulates the pitch of each key in the scale. This instrument is pre-set with some classical temperaments that are useful when playing older music, such as from the Renaissance period.

Please note that “Temperament” setting has NO effects on built-in songs and percussion sounds.

Function	Option	Default
Temperaments	Equal / Pure Major / Pure Minor / Pythagorean / Meantone / Werckmeister / Kirnberger / Arabic 1 / Arabic 2	Equal

## An Introduction to Classical Temperaments

### ■ Twelve-Tone Equal Temperament (12-TET)

12-TET is a tuning system that divides the octave into 12 equal intervals. This tuning system only has one type of half-tone and one type of whole-tone, making it easy to transpose. Most keyboard instruments worldwide are tuned in 12-TET.

### ■ Just Intonation Major and Minor (Pure Major and Minor)

Just Intonation is a tuning system that generates all other intervals using natural fifths and thirds. It works best for harmonies such as choral singing or solo singing.

However, due to the existence of two types of whole tones and half-tones, it is not suitable for keyboard instruments' design and performance.

### ■ Pythagorean Tuning (or 5-limit tuning)

Pythagorean Tuning is the earliest known tuning system in history, also known as the "cycle of fifths". It is named after Pythagoras, who developed this system based on the pure fifth interval. Compared to 12-TET, Pythagorean Tuning has larger whole tones and smaller half-tones.

### ■ Meantone Temperament

Mean-Tone Temperament was created to practically apply Just Intonation on keyboard instruments. One feature of this temperament is that it can produce consonant sounds that are very close to Just Intonation when forming triads. It was prevalent in Europe for hundreds of years, for its simpler construction compared to Just Intonation.

### ■ Werckmeister Temperament

Werckmeister Temperament is an improvement on the Pythagorean tuning system, proposed by the German organ craftsman and music theorist Andreas Werckmeister.

Its fifth interval preserves the essence of natural tuning and can play twelve different keys without the need for retuning. It was therefore praised by Bach as a temperament close to equal temperament.

Each key has a distinct color, which is an important basis for classical and romantic music's use of key names in titles, and the underlying reason for the revival of classical music scales.

### ■ Kirnberger Temperament

Kirnberger Temperament is a tuning system proposed by Johann Philipp Kirnberger, a student of Johann Sebastian Bach. After studying Bach's "Well-Tempered Clavier," Kirnberger developed a tuning system that is somewhat a combination of Mean-Tone Temperament and Just Intonation, and an improvement to the Mean-Tone Temperament.

### ■ Arabic Scale 1 and Arabic Scale 2

Two special Arabic-style scales with distinct regional characteristics.

■ **Temperament Key**

Establishing a standard key is crucial while using classical tunings other than 12-TET (“Equal”).

Temperament is based on the standard key that is used as a reference point for tuning the other keys. Changing the standard key will alter the foundation for tuning, resulting in different pitches across different keys and scales. To ensure proper tonality, it is recommended to set a standard pitch in accordance with the current piece when using non-12-TET temperaments.

Please note that the “Temperament Key” adjustment is only available when “Temperament” is set to non-“Equal”. When the default option of “Equal” is selected, adjustments are not possible.

Function	Option	Default
Temperament Key	C / C# / D / Eb / E / F / F# / G / Ab / A / Bb / B	- or C

■ **Twinova**

Twinova is a featured mode in which the entire keyboard is divided into two areas, left and right, with the same pitch and sound for both. This feature is particularly useful for elementary-level one-on-one instruction, and convenient for practicing and playing simple two-piano duets.

When set to “ON”, the Twinova mode is activated. For more details about Twinova mode, please refer to the Twinova Mode section (page 20).

Function	Option	Default
Twinova	ON / OFF	OFF

■ **Twinova Octave**

You have the option to transpose the pitch one octave down or up in Twinova mode. It is important to note that this feature only works in Twinova mode. For more details, please refer to the Twinova mode section (page 21).

Function	Parameter	Default
Twinova Octave	-1 ~ +1	0

## Global Effect Settings

■ **Reverb Type**

This simulates auditory experiences in spaces of different sizes and types. Choose the type that best suits your needs. Note that this affects all sounds, including performances, built-in songs, and MIDI playbacks.

Function	Option	Default
Reverb Type	Room / Saloon / Chamber / Symphony Hall / Church / Club	Chamber

■ **Reverb Level**

This adjusts the intensity of the selected reverb effect. Higher levels create a stronger sense of space, while lower levels reduce the effect. The instrument automatically selects a recommended reverb type and level when switching between sounds, but you can adjust the level to your preference. If set to 0, there will be no reverb effect applied.

Function	Parameter	Default
Reverb Level	0 ~ 127	64

■ **Chorus Type**

The chorus effect can enhance the depth and richness of your sound, and can also simulate unique effects found in certain instruments. Choose the chorus type that best suits your needs. Note that this affects all sounds.

Function	Option	Default
Chorus Type	Chorus 1 / Chorus 2 / Flanger / Rotary / Tremolo / Delay	Chorus 1

■ Chorus Level

Increasing the chorus level will make the effect of the corresponding chorus type more prominent. The instrument automatically selects an ideal chorus type with a recommended level when switching between sounds. You can adjust the depth yourself to suit your needs. Note that setting the chorus level to 0 will disable the chorus effect entirely.

Function	Parameter	Default
Chorus Level	0 ~ 127	0

■ D.A.S. (Dynamic Acoustic System)

This instrument features a powerful dynamic effect that equalizes higher and lower frequency bands during loud and quiet sessions, boosting balanced auditory experiences in general. D.A.S. is enabled by default.

Function	Option	Default
D.A.S.	ON / OFF	ON

■ Speaker EQ

This instrument offers a range of EQ (Equalizer) presets for different musical styles. You can choose a preset to better suit the piece you are performing or the song you are playing back. The default Speaker EQ is “Piano”, which is ideal for piano performance.

Function	Option	Default
Speaker EQ	Piano / Classical / Jazz / Pop / Rock / R&B	Piano

## Display Settings

■ Display Mode

To extend the lifespan of the screen and maintain optimal display quality, the OLED screen of the instrument automatically turns off or puts on a screen saver if the control panel is not in active use for a certain period of time depending on setting.

Function	Option	Default
Display Mode	ES / Auto	Auto

When set to the default option of “Auto”, the screen will begin looping an animated screen saver after a certain period of standby.

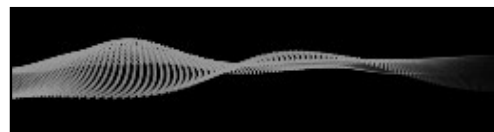

When set to “ES”, the screen will turn off after standby to save energy.

The touch panel on the instrument features backlit buttons for operation. However, if you find the lights distracting during longer play sessions or dim environments, the panel will go full dark after a certain period of inactivity, blending in with its surroundings.

To regain control, simply tap anywhere on the panel to wake it up.

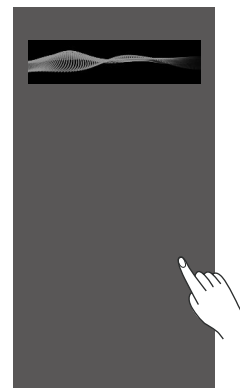

- **Dynamic Screen Saver in Piano Mode**

If the Display mode is set to “Auto”, the system will display an animated spectrum of your performance in real time.

If set to “ES”, the screen will turn off after a certain amount of time with no keyboard and panel operation.



- **Display Language**

This instrument supports Chinese and English for display. The default language is determined by your country/region.

Function	Option	Default
Language	Chinese / English	English

## Power Settings

- **Auto Power Off**

For energy conservation and safety, the piano includes an automatic power-off function that activates after a specified period of standby time. You can choose to set the time to either 15 or 60 minutes, or disable the function entirely by selecting the “Never” option.

Function	Option	Default
Auto Power Off	Never / 15min / 60min	15min

## MIDI I/O Settings

- **R1 out CH**

This determines the MIDI output channel for the signals produced by playing the “R1” part. The default setting is “1,” and selecting “OFF” will prevent signals from being transmitted.

Function	Option	Default
R1 out CH	1~16 / OFF	1

- **R2 out CH**

This determines the MIDI output channel for the signals produced by playing the “R2” part. The default setting is “2,” and selecting “OFF” will prevent signals from being transmitted.

Function	Option	Default
R2 out CH	1~16 / OFF	2

- **L out CH**

This setting determines the MIDI output channel for the signals produced by playing the “L” part. The default setting is “3,” and selecting “OFF” will prevent signals from being transmitted.

Function	Option	Default
L out CH	1~16 / OFF	3

- **Local Switch**

When this is set to “ON” (by default), the keyboard will produce sound using its built-in sound sources. Switching it to “OFF” will disable the instrument’s internal sound sources and allow it to function solely as a MIDI controller for triggering external sound sources.



## System Settings

The instrument has a built-in clock that allows you to set the date and time.

- **Date-Year**  
Set the year.
- **Date-Month**  
Set the month.
- **Date-Day**  
Set the day.
- **Time-Hour**  
Set the hour.
- **Time-Minute.**  
Set the minute.

Function	Parameter	Default
Date-Year	2020~2050	...
Date-Month	January ~ December	...
Date-Day	1~31	...
Time-Hour	0~23	...
Time-Minute	0~59	...

- **Speaker Mode**  
You can set the speaker mode so that the built-in speakers will produce sound when you are using headphones or Line output. This feature is very useful when the instrument's speakers are being used for onstage monitoring.

The current speaker mode icon will appear on the bottom of the main screen.

Function	Option	Default
Speaker Mode	Always ON / Always OFF / Auto	Auto



- **Touch Tone**  
The Touch Tone feature is on by default, providing feedback sound when you press a button. If you prefer, you can turn it off.



- **System Reset**  
You can choose to restore all settings to default.

1. The [-] button is unresponsive in this menu.  
Press [+] to proceed and the system will show a confirmation message. Press [+] once more to initiate the reset.
2. Selecting "No" will take you straight back to one of the modes (such as the Piano mode).  
Note that this operation will not affect the user track.

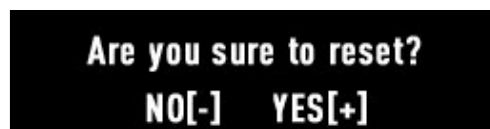

DO NOT cut off the power during the reset process as this may damage the instrument's system data.

You also have the option to perform a full factory reset.

To do so, follow these steps with the unit turned off:

1. Press and hold the first and third white keys from the left of the keyboard, then press the [POWER] button.
2. The screen should start up and prompt that the unit is now undergoing "Factory Resetting".  
This might take some time so please be patient and DO NOT cut off power until the unit starts up properly.

Please note that a factory reset will not only reset all settings but will also permanently delete any saved content in the user track. It is recommended to double-check before proceeding.

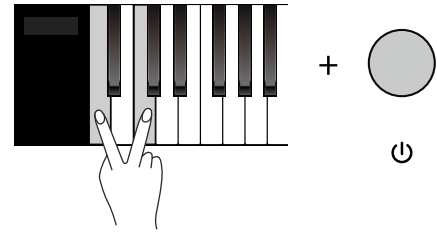

#### ■ System Version

Displays the instrument's current firmware version.

# Troubleshooting

Issues	Possible Cause and Solution
The instrument will not turn on, or it shuts down immediately after turning on	IMPORTANT! Make sure you are using the standard power adapter provided with the instrument, and check that the plugs are securely connected.
There is a slight noise when powering on or off	This is normal and not a cause for concern.
Buttons do not respond	Some buttons on the panel are disabled in certain menus. When the touch tone feature (page 37) is on, you can check if the button is currently disabled by whether there's a feedback sound.
The speakers of the instrument do not sound when playing keyboards or rolling playbacks	Check if the [VOLUME] knob is set too low. If so, turn clockwise to increase the volume.
	Check if the volume for each sound part or playback is set too low. If so, adjust accordingly. (page 29)
	Unplug headphones or convertors from [PHONES] jacks.
	The speaker mode may be set as "Always OFF". (page 37)
The instrument makes noise	When using a mobile phone nearby (especially when receiving calls), the instrument might make noise due to interference. Move the mobile phone slightly away from the instrument.
The keyboard is not touch sensitive	Certain sounds are NOT touch-sensitive due to their characteristics.
	Check if the touch response (page 32) is turned off. If so, turn it on.
The pitch is not accurate	Check if the classical temperament (page 32) is set to non-"Equal". If so, set it to back to "Equal".
	Check if pitch shift functions (page 19, 32) are set to non-"0". If so, reset to "0".
The file name in the USB drive is not displayed properly	The instrument supports Chinese and English displays. If the file name contains characters & symbols unrecognized by the system, it may be displayed improperly.
When connecting to a PC, the PC does not recognize it	This unit does not require a driver to be able to connect to a PC. Check if the USB cable is firmly plugged or try switching to another USB port on the PC.
Pedaling feels unstable	Make sure that the support bolts at the bottom of each pedal is fully attached to the ground and not hanging.
Some menus are not displayed in English	This is caused by the limited memory during the initialization of the system's language resources, which is normal.

\* If you encounter any malfunction that you cannot resolve on your own, please refer to our company's product warranty regulations and contact the supplier or designated maintenance station.

# Specifications

Display	Screen	256 × 64 OLED
	Mode	ES (Energy Saving) / Auto
	Language	English / Chinese
Physical Controls	Control Panel	Capacitive touch panel with backlit buttons
Keyboard	Specs	G3P: Progressively weighted, three-contact keyboard with escapement
	Touch Response	OFF / Soft 2 / Soft 1 / Normal / Hard 1 / Hard 2
Sounds	Piano Sounds	PurePiano
	Polyphony	256
	Number of Sounds	40
	Number of Sound Demos	26
	Sound Parts	L (Left), R1 (Right 1), R2 (Right 2)
Performance	Piano Mode	Yes
	Sound Mode	Yes
	Twinova Mode	Yes (transposing -1 / +1 octave supported)
	Part Combinations	R1, R2 (Layered); R1, L (Split); R1, R2 and L (Layered and Split)
	Brilliance Adjustment	Yes
Piano Effects	Damper Resonance	0~10
	Damper Noise	0~10
	String Resonance	0~10
	Lid Angle	Open / Half / Close
	Open String Resonance	0~10
	Key Off Effect	OFF / Low / Normal / High
	Soft Pedal	0~10
	Ambience	6 types
	Ambience Depth	0~10
	Body Resonance	0~10
Global Effects	Reverb Settings	6 types and 0~127 depth adjustment
	Chorus Settings	6 types and 0~127 depth adjustment
	D.A.S	ON / OFF
	Speaker EQ Type	6 types
Songs & Lessons	Classical Category	100 world-famous piano pieces
	MIDI Recording	1 local recording supported
		Multiple recordings via USB drive supported, with the total number of recordings depending on the storage capacity of the connected drive
	Audio Playback Formats	.wav (44.1kHz, 16bit) / .mp3 (320kbps) / .m4a
Audio Recording Formats	.wav (44.1kHz, 16bit) / .mp3 (320kbps) (Maximum recording time per file is 90 minutes, with the total number of recordings depending on the storage capacity of the connected drive)	

Songs & Lessons	Lesson Collections	1 - Vorschule Im Klavierspiel, Op.101 (Beyer)
		2 - Practical Exercises for Beginners, Op.599 (Czerny)
		3 - 30 Études de Mécanisme, Op.849 (Czerny)
		4 - 25 Études faciles et progressives, Op.100 (Burgmuller)
		5 - 16 Selections from The Virtuoso Pianist (Hanon)
	Number of Lesson Tracks	320
	Part Muting	Left / right-hand part
Play to search via AI	AI recognition through playing single/both-hand parts of built-in piano tracks	
Functions	Auto Power Off	15min / 60min / Never
	Tempo	5~320 BPM, tempos / tempo markings cross-referencing supported
	Transpose (semitone)	-12 ~ +12 Semitone
	Master Tune	415.4Hz~466.2 Hz
	Classical Temperaments	9 classical temperaments with standard key adjustment
	Metronome.	Accent Bell ON / OFF, 14 time signatures
	Touch Tone	ON / OFF
	Local Keyboard Sound	ON / OFF
	System Reset	Yes
	Time	Year, Month, Day, Hour, Minute
	Speaker Mode	Always ON / Always OFF / Auto
Connectivity	Pedals	3 Progressive Response Grand Piano Pedals
	USB TO HOST	MIDI recording via software / two-way audio transmission supported
	USB TO DEVICE	Compatible with FAT32 format USB drive up to 128gb storage space
	PHONES	Stereo phone jack (3.5mm x 1 & 6.5mm x 1)
	AUX IN	Mini stereo jack (3.5mm x 1)
	LINE OUT	Stereo jack [L / L+R, R] (6.5mm x 2)
Digital Contents	Recording App	Supports audio and video recording, compatible with iOS and Android devices
		Maximum recording time is 20 minutes per audio or 10 minutes per video
	Digital Score	100 classical piano score PDF collection
Sound System	Amplifier Wattage	25Wx2 + 25Wx2
	Speaker Wattage	25Wx2 + 8Wx 2
	Speaker Size	12cmx2 + 5cmx2
Power Usage	DC 15V / 2500mA	
Weight	55kg	
Dimensions (L x W x H)	1408 x 448 x 913mm	

# Sound List

No	Bank MSB	Bank LSB	Program	Sound Name	Left Pedal Function
<b>Piano</b>					
1	121	12	0	Concert Full X Grand	
2	121	11	0	Model D Concert Grand	
3	121	10	0	Pop Piano	
4	121	11	1	Real Bright Piano	
5	121	11	3	Real Honky Tonk	
6	121	10	1	Upright Piano	
7	121	16	1	Piano & EP	
8	121	10	6	Real Harpsichord	
9	121	11	6	Harpsichord 8+4	
<b>E.Piano</b>					
10	121	11	5	Dream Electric Piano	Modulation ON / OFF
11	121	10	4	MK Electric Piano	Modulation ON / OFF
12	121	10	5	DX7 Electric Piano	Modulation ON / OFF
13	121	11	4	WLZ Electric Piano	Modulation ON / OFF
14	121	10	7	Clavi D6	
15	121	11	7	Clavi D6 Amp	
<b>Organ &amp; Accordion</b>					
16	121	0	16	Stereo Drawbar Organ	Rotary Speed (Fast, Slow)
17	121	13	18	Stereo Rock Organ	Rotary Speed (Fast, Slow)
18	121	0	19	Real Church Organ	
19	121	1	19	Octave Church Organ	
20	121	10	21	Musette	
21	121	11	21	Real Accordion	
<b>Guitar &amp; Bass</b>					
22	121	10	24	Real Nylon Guitar	Guitar Sound Effect
23	121	10	25	Real Steel Guitar	Guitar Sound Effect
24	121	12	27	Slide Clean Guitar	Guitar Sound Effect
25	121	12	33	Real Finger Bass	Bass Sound Effect
26	121	11	32	Real Acoustic Bass	Bass Sound Effect
<b>Strings</b>					
27	121	10	48	Real Strings	
28	121	0	48	Classic Strings	
29	121	1	48	Orchestra Tutti	
30	121	11	48	Concert Strings	
31	121	0	46	Real Harp	
32	121	0	50	Cool Synth Strings	
<b>Lead &amp; Pad</b>					
33	121	10	80	Wire Lead	Portamento ON / OFF
34	121	16	84	Dance Lead	Portamento ON / OFF
35	121	15	91	Dream New Age	
36	121	12	88	Bright New Age	
<b>Perc. &amp; Drums</b>					
37	121	1	11	Cool Vibraphone	Modulation ON / OFF
38	121	1	12	Real Marimba	
39	121	10	8	Real Celesta	
40	120	0	0	Standard Set	

# Sound Demo List

No	Title	Composer
1	Set Sail	Original
2	Valse in A Minor	Chopin
3	Latin Piano	Original
4	Latin Bar	Original
5	Neo-Baroque 1	Original
6	Neo-Baroque 2	Original
7	Heart of Youth	Original
8	Smooth Flow	Original
9	Sweet Dream 1	Original
10	Sweet Dream 2	Original
11	Magic EP	Original
12	Funk Beat 1	Original
13	Funk Beat 2	Original
14	Fusion Band	Original
15	Rock of Ages	Original
16	Toccatà and Fugue in D Minor	J.S.Bach
17	Variations BWV.769 Part	J.S.Bach
18	Encounter in Paris	Original
19	Accordion & Tango	Original
20	Unplugged	Original
21	Acoustic Dance	Original
22	Sunrise Time	Original
23	Space Odyssey	Original
24	The Smell of Spring	Original
25	The Mystery Room 1	Original
26	The Mystery Room 2	Original

# Classic List

No	Title	Composer
1	Sonata No.17 in D Minor, Op.31 No.2 3rd Mov.	Beethoven
2	Sonata No.14 in C-Sharp Minor, Op.27-2 1st Mov.	Beethoven
3	Sonata No.8 in C Minor, Op.13 2nd Mov.	Beethoven
4	Sonata No.25 in G Major, Op.79 1st Mov.	Beethoven
5	Sonata No.20 in G Major, Op.49 No.2 1st Mov.	Beethoven
6	Bagatelle No.25 in A Minor, WoO 59, 'Für Elise'	Beethoven
7	Menuett G-Dur 4	Beethoven
8	Prelude and Fugue No.1 in C Major, BWV.846	J.S.Bach
9	Suite No.2 in A Minor, BWV.807, Prelude	J.S.Bach
10	Suite No.5 in G Major, BWV.816, Gavotte	J.S.Bach
11	Minuet in G Major, BWV Anh.114	J.S.Bach
12	Prelude in C-Sharp Major, BWV.848	J.S.Bach
13	Prelude in E Major	J.S.Bach
14	Prelude in C Minor	J.S.Bach
15	Two-Part Invention No.13 in A Minor, BWV.784	J.S.Bach
16	Two-Part Invention No.1 in C Major, BWV.772	J.S.Bach
17	Sonata No.15 in C Major, K.545 1st Mov.	Mozart
18	Sonata in B-Flat Major, K.333 1st Mov.	Mozart
19	Sonata in B-Flat Major, K.333 3rd Mov.	Mozart
20	Sonata No.11 in A Major, K.331 3rd Mov., 'Rondo alla Turca'	Mozart
21	12 Variations on 'Ah, Vous Dirai-je, Maman', KV.265	Mozart
22	Perpetuum Mobile	Weber
23	Impromptu Op.90 No.2 in E-Flat Major, D.899	Schubert
24	Moments Musicaux Op.94 No.3	Schubert
25	Serenade	Schubert
26	Sonatina No.1 in C Major, Op.36 1st Mov.	Clementi
27	Sonatina No.2 in G Major, Op.36 1st Mov.	Clementi
28	Sonatina No.3 in C Major, Op.36 1st Mov.	Clementi
29	Sonatina No.4 in F Major, Op.36 1st Mov.	Clementi
30	Etude Op.10 No.1 in C Major	Chopin
31	Etude Op.10 No.3 in E Major, 'Chanson de l'adieu'	Chopin
32	Etude Op.10 No.5 in G-Flat, 'Black Keys'	Chopin
33	Etude Op.10 No.12 in C Minor, 'Revolutionary'	Chopin
34	Etude Op.25 No.1 in A-Flat Major	Chopin
35	Etude Op.25 No.2 in F Minor	Chopin
36	Nocturne in B-Flat Minor, Op.9 No.1	Chopin
37	Nocturne in E-Flat Major, Op.9 No.2	Chopin
38	Nocturne in F Minor, Op.55 No.1	Chopin
39	Impromptu No.1 in A-Flat Major, Op.29	Chopin
40	Fantaisie-Impromptu, Op.66	Chopin
41	Prelude No.15 in D-Flat Major, Op.28, 'Raindrop'	Chopin
42	Preludes No.20 in C Minor, Op.28	Chopin
43	Waltz in E-Flat Major, Op.18, 'Grande Valse Brillante'	Chopin
44	Waltz in C-Sharp Minor, Op.64 No.2	Chopin
45	Waltz in D-Flat Major, Op.64 No.1, 'Minute'	Chopin
46	Mazurkas in F Major, Op.68 No.3	Chopin
47	Nocturne in C-Sharp Minor, Op.Posth., B.49	Chopin
48	Song Without Words, Op.19b No.1 in E Major, 'Sweet Remembrance'	Mendelssohn
49	Song Without Words, Op.62 No.1 in G Major, 'May Breezes'	Mendelssohn
50	Song Without Words, Op.62 No.6 in A Major, 'Spring Song'	Mendelssohn

No	Title	Composer
51	Song Without Words, Op.30 No.6 in F-Sharp Minor, 'Venetianisches Gondellied'	Mendelssohn
52	Song Without Words, Op.67 No.2 in F-Sharp Minor, 'Lost Illusions'	Mendelssohn
53	The Seasons No.6, June-Barcarolle	Tchaikovsky
54	The Seasons No.10, October-Autumn Song	Tchaikovsky
55	The Seasons No.12, December-Christmas	Tchaikovsky
56	Neapolitan Song	Tchaikovsky
57	Kinderszenen Op.15 No.7, 'Traumerei'	Schumann
58	Album for the Young, Op.68 No.1, 'Melody'	Schumann
59	Album for the Young, Op.68 No.10, 'The Happy Farmer'	Schumann
60	Album for the Young, Op.68 No.13, 'May, Sweet May'	Schumann
61	Album for the Young, Op.68 No.38, 'Winter Time I'	Schumann
62	Scenes from Childhood, Op.15 No.1, 'About Strange Lands and People'	Schumann
63	Intermezzo No.2 in A Major, Op.118	Brahms
64	Waltz No.15 in A-Flat Major, Op.39	Brahms
65	Arabesques No.1, 'Andantino Con Moto'	Debussy
66	Deux Arabesques No.2	Debussy
67	Suite Bergamasque No.3, L.75, 'Clair De Lune'	Debussy
68	Perludes No.8, 'La Fille Aux Cheveux De Lin'	Debussy
69	Children's Corner, 'Doctor Gradus Ad Parnassum'	Debussy
70	Reverie, L.68	Debussy
71	Golliwog's Cakewalk	Debussy
72	Lyric Pieces Op.12 No.1, 'Arietta'	Grieg
73	Lyric Pieces Op.43 No.1, 'Butterfly'	Grieg
74	Gymnopedies No.1, 'Lent Et Doreux'	Satie
75	Je Te Veux	Satie
76	Romanian Folk Dances, No.6, Fast Dance	Bartok
77	Sonata in F Major, Hob. XVI 23, I. Allegro	Haydn
78	Gypsy Rondo	Haydn
79	Liebstraum No.3 in A-Flat, S.541 No.3	Liszt
80	The Sapin, Op.75 No.5	Sibelius
81	Etudes-tableaux Op.33, No.7 in G Minor	Rachmaninoff
82	Lyric Rondo	C.P.E.Bach
83	Solfeggio	C.P.E.Bach
84	Humoresque	Dvorak
85	La Priere D'une Vierge	Badarzewska
86	To A Wild Rose	MacDowell
87	Fontaine, La	Karl Bohm
88	Blumenlied	Gustav Lange
89	Le Coucou	Claude Daquin
90	Minuet	Boccherini
91	Warblings At Eve	Richards
92	Gavotte	Gossec
93	Dance Steps	Scarlatti
94	Salut D' Amour	Elgar
95	Le Cygne	Saens
96	Paloma, La	Yradier
97	Rialto Ripples	Gershwin
98	Maple Leaf Rag	Joplin
99	The Entertainer	Joplin
100	Peacherine Rag	Joplin

# Lesson List

Lesson	No	Collection/Song	Composer
1	1~129	Vorschule Im Klavierspiel, Op.101	Beyer
2	130~229	Practical Exercises for Beginners, Op.599	Czerny
3	230~259	30 Études de Mécanisme, Op.849	Czerny
4	260~284	25 Études faciles et progressives, Op.100	Burgmüller
	260	No.1 in C Major, La candeur	
	261	No.2 in A Minor, L'arabesque	
	262	No.3 in G Major, La pastoral	
	263	No.4 in C Major, La petite reunion	
	264	No.5 in F Major, Innocence	
	265	No.6 in C Major, Progres	
	266	No.7 in G Major, Le courant limpide	
	267	No.8 in F Major, La gracieus	
	268	No.9 in C Major, La chasse	
	269	No.10 in D Major, Tendre fleur	
	270	No.11 in C Major, La bergeronnette	
	271	No.12 in A Major, L'adieu	
	272	No.13 in C Major, Consolation	
	273	No.14 in G Major, La styrienne	
	274	No.15 in C Minor, Ballade	
	275	No.16 in G Minor, Douce plainte	
	276	No.17 in F Major, La babillarde	
	277	No.18 in E Minor, Inquiétude	
	278	No.19 in A Major, Ave Maria	
	279	No.20 in D Minor, La tarentelle	
	280	No.21 in G Major, L'harmonie des anges	
	281	No.22 in A-Flat Major, Barcarolle	
	282	No.23 in E-Flat Major, Le retour	
	283	No.24 in G Major, L'hirondelle	
	284	No.25 in C Major, La chevaleresque	
5	285~320	16 Selections from The Virtuoso Pianist	Hanon

# MIDI Implementation List

	Function	Transmitted	Recognized	Remarks
Basic Channel	Default Changed	1ch ×	1-16ch ×	
Mode	Default Messages Altered	×	×	
Note Number	True sound	0-127 *****	0-127 0-127	
Velocity	Note on Note off	○ 99H,V=1-127 ○ 99H,V=0	○ 9nH,V=1-127 ○ 9nH,V=0;8nH,V=0-127	
After Touch	Key's Channel	×	○ ×	
Pitch Bend		×	○	
Control Change	0 1 5 6 7 10 11 64 65 66 67 80 81 91 93 120 121 123	○ × × × ○ × × ○ × × ○ ○ ○ ○ × × × × × × ×	○ ○	Bank Select Modulation Portamento Time Data Entry Volume Pan Expression Sustain Pedal Portamento On/Off Sostenuto Pedal Soft Pedal Reverb Program Chorus Program Reverb Level Chorus Level All Sound Off Reset All Controllers All Notes Off
Program Change	True Number	×	○	
System Exclusive		×	○	
System Common	Song Position Song Select Tune Request	×	×	
System Real Time	Clock Commands	×	×	
Aux Messages	Local ON/OFF All Notes Off Active Sensing System Reset	×	×	
Notes				

Mode 1: OMNI ON, POLY  
Mode 3: OMNI OFF, POLY

Mode 2: OMNI ON, MONO  
Mode 4: OMNI OFF, MONO

○ : YES  
× : NO

